

LIST OF CONTENTS

| | |
|---|-----------|
| 1. DESCRIPTION..... | 5 |
| 1.1 Manual Structure | 5 |
| 1.2 NOVAR 1106/1114/1206/1214 Essential Functions | 5 |
| 1.3 NOVAR Controller Version “/S400” | 6 |
| 1.4 NOVAR 1005 / 1007..... | 6 |
| 1.5 NOVAR 1312..... | 6 |
| 1.6 History of Firmware Versions..... | 6 |
| 1.7 Front Panel..... | 7 |
| 1.8 Numeric Display | 7 |
| 1.8.1 NOVAR 11xx / 12xx / 13xx Controllers..... | 7 |
| 1.8.1.1 Instantaneous Measurement Values..... | 7 |
| 1.8.1.2 Main Branch | 7 |
| 1.8.1.2.1 COS Branch | 9 |
| 1.8.1.2.2 A Branch | 10 |
| 1.8.1.2.3 V Branch | 11 |
| 1.8.1.3 Controller Parameters | 12 |
| 1.8.2 NOVAR 10xx Controllers..... | 13 |
| 1.8.3 Test and Error Messages | 13 |
| 1.9 Indication LEDs | 13 |
| 1.9.1 Output State Indications | 14 |
| 1.9.2 Trend Indication | 14 |
| 1.9.3 Indication of Manual Mode | 14 |
| 1.9.4 Indication of Backfeed (Power Export) | 14 |
| 1.9.5 Alarm Indication | 14 |
| 2. INSTALLATION..... | 15 |
| 2.1 Physical..... | 15 |
| 2.2 Connection..... | 15 |
| 2.2.1 Power Supply..... | 15 |
| 2.2.1.1 Standard Version Controllers | 15 |
| 2.2.1.2 “/S400” Version Controllers | 16 |
| 2.2.1.3 NOVAR 1005 / 1007 Controllers | 16 |

| | |
|---------|--|
| 2.2.1.4 | Protection |
| 2.2.2 | Measurement Voltage |
| 2.2.2.1 | 11xx and 10xx Line Controllers |
| 2.2.2.2 | 12xx Line Controllers |
| 2.2.3 | Measurement Current |
| 2.2.4 | Error Indication |
| 2.2.4.1 | NOVAR 11xx / 12xx / 13xx Controllers |
| 2.2.4.2 | NOVAR 10xx Controllers |
| 2.2.5 | Output Relays |
| 2.2.5.1 | Standard Version Controllers |
| 2.2.5.2 | "/S400" Version Controllers |
| 2.2.6 | Second Metering Rate, External Alarm |
| 2.2.7 | Communication Interface |
| 2.2.7.1 | RS-232 Communication Interface |
| 2.2.7.2 | RS-485 Communication Interface |

3. PUTTING IN OPERATION

| | |
|-----|--|
| 3.1 | First Use |
| 3.2 | Automatic connection configuration detection process |
| 3.3 | Automatic Section Power Recognition Process |

4. OPERATION

| | |
|----------|---|
| 4.1 | Setup |
| 4.1.1 | Editing Parameters and Clearing Recorded Measurement Values |
| 4.1.1.1 | Parameter Editing |
| 4.1.1.2 | Clearing Recorded Measurement Values |
| 4.1.1.3 | Enable / Disable Parameter Edit |
| 4.1.2 | Parameter 01/07 – Target Power Factor |
| 4.1.3 | Parameter 02/08 – Undercompensation Control Time |
| 4.1.4 | Parameter 03/09 – Overcompensation Control Time |
| 4.1.5 | Parameter 04/10 – Control Bandwidth on High Loads |
| 4.1.6 | Parameter 06 – Metering Rate 2 Operation |
| 4.1.7 | Parameters 12,13 – Metering Current Transformer (CT) Ratio |
| 4.1.8 | Parameter 14 – Reconnection Delay Time |
| 4.1.9 | Parameters 15, 16 – Type of Measurement Voltage and Connection Configuration |
| 4.1.9.1 | Setting Type of Connection Configuration if Measuring at Power Supply Opposite Sides |
| 4.1.10 | Parameter 17 – Metering Voltage Transformer (VT) Turns Ratio |
| 4.1.11 | Parameter 18 – Compensation System Nominal Voltage (U_{NOM}) |
| 4.1.12 | Parameter 20 – Automatic Section Power Recognition Process |
| 4.1.13 | Parameter 21, 22 – Switching Program, Selection of Linear Switching Mode Capacitor (C/k_{MIN}) Nominal Power |
| 4.1.14 | Number of Capacitors |
| 4.1.15 | Parameter 25 – Compensation Section Nominal Power |
| 4.1.16 | Parameter 26 – Fixed Sections, Switching Cooling and Heating, Alarm |
| 4.1.16.1 | Fixed Sections |
| 4.1.16.2 | Switching Cooling and Heating |
| 4.1.16.3 | Alarm Signalling (NOVAR 10xx only) |
| 4.1.17 | Parameter 27 – Limit Power Factor for Compensation by Choke |
| 4.1.18 | Parameter 30 – Alarm Setting |
| 4.1.18.1 | Alarm Indication |
| 4.1.18.2 | Alarm Actuation |
| 4.1.19 | Parameters 31 through 37 – Alarm Indication/Actuation Limits |
| 4.1.20 | Parameter 40 – Alarm Status |

| | | |
|-------------|---|-----------|
| 4.1.21 | Parameters 43, 44 – Total Section Connection Time and Number of Section Switching Operations..... | 39 |
| 4.1.22 | Parameter 45 – Type of Controller Error | 39 |
| 4.1.23 | Parameter 46 – Control Time | 40 |
| 4.1.24 | Parameters 50, 51, 52 – Instrument Address, Communication Rate and Communication Protocol..... | 40 |
| 4.1.25 | Parameter 55 – Power System Frequency..... | 40 |
| 4.1.26 | Parameters 56, 57 – average, maximum, minimum value evaluation window size..... | 41 |
| 4.1.27 | Parameter 58 – Temperature Display °C / °F | 41 |
| 4.1.28 | Parameters 59, 60 – Cooling and Heating Switching Thresholds | 41 |
| 4.2 | Section Value Accurization | 41 |
| 4.3 | Faulty Section Indication and Disablement..... | 42 |
| 4.4 | Compensation by Choke | 43 |
| 4.5 | Control Interruption | 44 |
| 4.6 | Manual Mode..... | 44 |
| 4.7 | Manual Intervention in Control Process | 44 |
| 4.8 | Controller Initialization | 45 |
| 4.9 | Capacitor Harmonic Load factor (CHL)..... | 45 |
| 4.10 | Text Messages..... | 48 |
| 5. | NOVAR1312 DESCRIPTION..... | 49 |
| 5.1 | Basic Operation..... | 49 |
| 5.2 | History of Firmware Versions..... | 49 |
| 5.3 | Installation | 49 |
| 5.3.1 | Transistor Outputs | 49 |
| 5.3.2 | Relay Outputs | 50 |
| 5.4 | Operation | 50 |
| 5.4.1 | Thyristor and Contactor Group | 50 |
| 5.4.2 | Control Principles..... | 50 |
| 5.5 | Setup | 51 |
| 5.5.1 | Parameter 28 – Number of Capacitors in Thyristor Group | 51 |
| 5.5.2 | Parameter 29 – Thyristor Group Control Rate and Reconnection Delay Time..... | 51 |
| 5.5.2.1 | Control Operation at the Highest Control Rate..... | 52 |
| 6. | WIRING EXAMPLES | 55 |
| 7. | TECHNICAL SPECIFICATIONS | 64 |
| 8. | MAINTENANCE, TROUBLESHOOTING | 66 |

1. Description

1.1 Structure of this Manual

The manual has two principal parts. The first one describes NOVAR 1106, NOVAR 1114, NOVAR 1206 and NOVAR 1214 power factor controllers including "/S400" version, and simple NOVAR 1007 and NOVAR 1007 models.

NOVAR 1312 power factor controller, designed for rapid power factor compensation, uses concepts of NOVAR1214; most of their features and operations are identical. That is why NOVAR1312 is in a separate chapter at the end of this manual, and it covers specific features of that controller only.

1.2 NOVAR 1106/1114/1206/1214 - Essential Functions

NOVAR 1xxx reactive power controllers are fully automatic instruments that allow optimum reactive power compensation. They take their design concepts from the series NOVAR 1 bringing up a number of improvements and new features while keeping the way of operation.

The instruments feature precise voltage and current measurement circuits, while the digital display of values measured provides high evaluation accuracy of both true root-mean-square voltage, current and power factor values. The built-in temperature sensor measures the temperature inside the distribution board cubicle.

The instruments calculate fundamental harmonic component of active and reactive current using a digital algorithm. Voltage fundamental harmonic component is calculated in an analogous manner providing accurate measurement and control even in conditions of distortion by higher harmonic components.

The voltage measurement circuit of the NOVAR 1106/1114 is internally connected to the terminals; it is insulated in NOVAR1206/1214, allowing connection of any voltage within the range from 45 to 760 V AC. The power system frequency can vary within the range from 43 to 63 Hz. The current measurement input is a general-purpose one for nominal value of 1 A or 5 A meter transformer's secondary side. The measurement inputs can be connected to the controller in any combination, that is any phase or line voltage and any phase's current.

The instrument's installation is fully automatic. The controller automatically detects both the connection configuration and the value of each compensation section connected. Entering parameters manually is also possible.

Control is provided in all four quadrants and its speed depends on both control deviation and polarization (overcompensation / undercompensation). Connecting and disconnecting power capacitors is carried out in such a way that achieving the optimum compensation condition requires a single control intervention at minimum number of sections connected. At the same time, the instrument chooses relay sections with regard to their even load and preferably connects sections that have been disconnected for the longest time and the remanent charge of which is thus minimum. Within the control process the instrument continually checks the relay compensation sections; if a section's outage or change in value is detected, the section is temporarily disabled for a period under relevant setting. The section temporarily disabled is periodically tested and enabled again when possible.

In measurement, harmonic component levels of both voltage and current are evaluated up to 15th order. The current's Total Harmonic Distortion, THD, and the Capacitor Harmonic Load, CHL, can be viewed on a display, are calculated from these measurements' results while it is possible to set the THD and the CHL threshold levels at which the controller disconnects all compensation sections thus preventing their damage. Besides that, the most adverse values are recorded into the instrument's memory for subsequent analysis.

Besides the power factor capacitors, it is possible to connect power factor chokes (power system decompensation). Any output can be set as fixed, the two highest outputs can also be used to connect the cooling or heating circuits.

The controllers come in two basic designs with different numbers of outputs: NOVAR1106/1206 with six output relays and NOVAR1114/1214 with fourteen output relays. The NOVAR12xx controllers have, as opposed to the 11xx line, an additional voltage measurement input and a second metering rate input.

Both types of controller have an Alarm relay output that can be set to indicate non-standard conditions, such as undercurrent, overcurrent, measurement voltage failure, overvoltage, harmonic distortion preset threshold exceeded, overcompensation or undercompensation, section limit connection rate exceeded, section outage, backfeed condition (power export) or overheating.

All types of the controller can be ordered in a version featuring an optional galvanic-insulated RS-232 or RS-485 communication interface. All values measured can be then monitored and the controller's parameters set using a remote computer.

1.3 NOVAR Controller Version "/S400"

Controllers of version "/S400" (model marking example : NOVAR-1114/S400) differ from standard version of the NOVAR-1106 / NOVAR-1114 / NOVAR-1206 / NOVAR-1214 models in following aspects :

- increased maximum power supply voltage up to 500 V, both AC and DC
- relays' common contacts insulated, connected to additional terminals

The "/S400"-version instruments can be used at insulated networks (without neutral wire). The other features are identical to those of standard version.

1.4 NOVAR1005 / 1007

These models are simplified versions of the NOVAR1106 / 1114 models. They are built in smaller box and designed for less demanding applications. NOVAR1005 features 6 output relays, NOVAR1007 features 8 output relays.

1.4.1.5 NOVAR1312

NOVAR1312 is designed to provide rapid compensation using thyristor switches. It differs from NOVAR1214 in the two following principal aspects:

- outputs 1 through 12 are transistor-driven
- control speed for these outputs can be set up to 25 interventions a second

NOVAR1312 specific features are described in a separate chapter. The other features are identical to those of NOVAR1214.

1.5.1.6 History of Firmware Versions

| version | date of release | note |
|---------|-----------------|--|
| 1.0 | 3/2006 | - basic version |
| 1.1 | 4/2007 | - 2nd metering rate functionality bug fix - linear switching mode added to parameter 21 |
| 1.2 | 9/2007 | - external alarm (No. 14) function added |

4.61.7 Front Panel

The front panel consists of a numeric display, indication LEDs and control keys.

Figure 1.1: Front Panel



4.7.1.8 Numeric Display

Information shown on the numeric display can be divided into 3 main data groups:

- instantaneous power system values measured, such as power factor, current power, etc.
- controller parameters
- test and error messages

4.7.1.8.1 NOVAR 11xx / 12xx / 13xx Controllers

4.7.1.8.1.1 Instantaneous Measurement Values

The mode of displaying instantaneous values is the basic display mode which the controller enters after power-up. If you switch to parameter display mode, you can get back to instantaneous value mode by pressing the **M** (Measurement) button.

The controller enters the instantaneous display mode automatically in about 30 seconds after power-up. If you stop pressing control keys (or in five minutes if control time is displayed – see parameter 46 further below).

4.7.1.8.1.2 Main Branch

One LED, **COS** or **A** or **V**, is always lit in the instantaneous display mode. These LEDs indicate the value group displayed. Instantaneous values displayed are organized in branches – see

The main branch contains the following main instantaneous values: **cos**, **I_{eff}** and **U_{eff}**. You can switch between the values displayed using the **▲**, **▼** buttons.

Figure 1.2: Instantaneous value display – structure

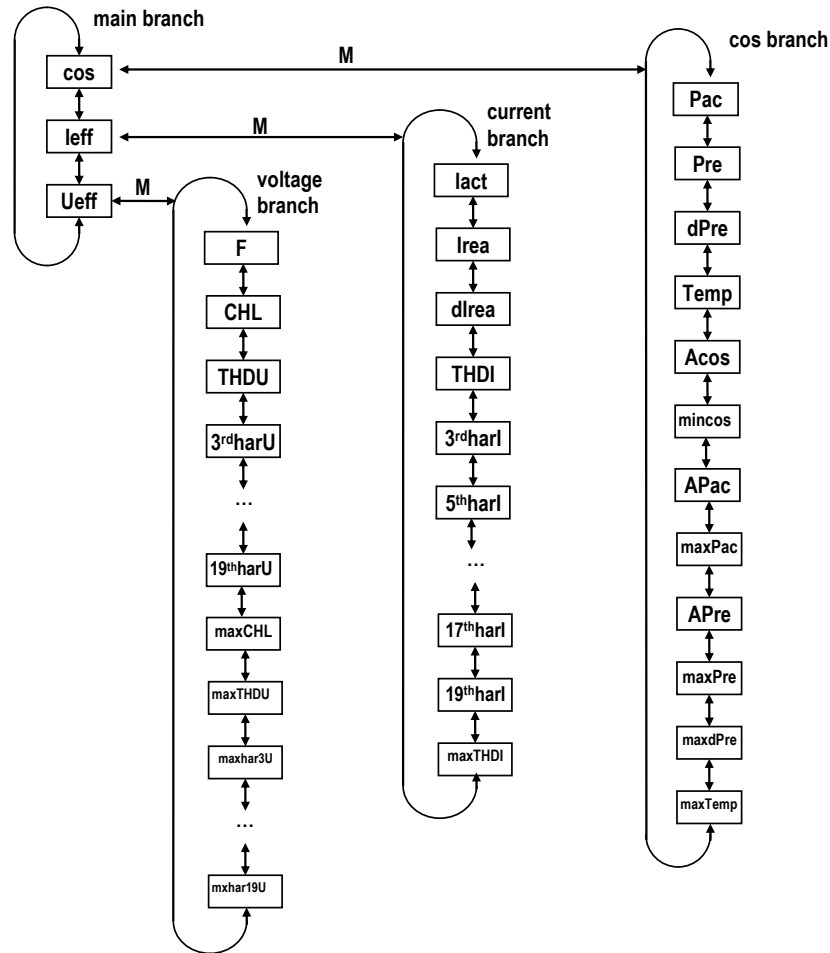

Table 1.1: List of Measurement Quantities – Main Branch

| abbreviation | symbol | quantity | unit |
|--------------|--------|--|----------|
| cos | - | Instantaneous power factor. The value corresponds to the ratio of instantaneous active component to instantaneous total power fundamental harmonic value in the power system. A positive value means inductive power factor, negative means capacitive power factor. | - |
| Ieff | - | Instantaneous current effective value in the power systems (including higher harmonic components). | A / kA * |
| Ueff | - | Instantaneous voltage effective value in the power system (including higher harmonic components). By default shown in volts. If the measurement voltage is connected via a metering transformer, in kilovolts (see description of parameter 17). | V (kV) |

* ... in A as default; flashing decimal point indicates value in kA

Pressing the **M** button switches to the relevant subbranch: to the branch of power factors temperature while displaying **COS** (further as COS Branch), to the current branch while c (further as A Branch) or to the voltage branch while displaying **Ueff** (further as V Branch) can move up and down the branch using the **▲**, **▼** buttons. Displaying values of the sul quantities is indicated with periodic flashes of the quantity symbol. To get back to the ma instantaneous values press button **M**.

Tables 1.1 through 1.4 show descriptions of the measurement quantities.

4.7.1.2.1.8.1.2.1 COS Branch

Instantaneous power values as well as recorded average, maximum and minimum value quantities are shown in the COS Branch. Power is displayed as three-phase values (sing power values multiplied by three). Reactive power values are prefixed with L for positive for negative values.

The values recorded can be divided by their nature into three groups:

1. Average values **Acos**, **APac**, **APre**

These are average values of power factor, active and reactive power. The depth can be set in parameter 56 from 1 minute to 7 days.

Note: The average values of active and reactive power are rendered with the sig example, the reactive power value is changing its polarity (it has alternately indu capacitive character), its average value, **APre**, may become zero even though tl instantaneous reactive power value was not zero at any point in time under eval the power factor average value, which is evaluated from the average active and power using the formula

$$\text{Acos} = \frac{\text{APac}}{\sqrt{\text{APac}^2 + \text{APre}^2}}$$

may, in such an event, become 1 even though the instantaneous power factor w within the time evaluated.

2. Maximum and minimum values **mincos**, **maxPac**, **maxPre**, **maxdPre**

- **mincos** – evaluated as a ratio of fundamental harmonic active and rea moving averages. The moving average window size can be specified ir 57 from 1 minute to 7 days. The minimum value is recorded and displa Evaluation is conditioned by the corresponding average current being ; the nominal load as determined from the metering current transformer primary value (parameter12) else the value is ignored (the value is not minimum loads).
- **maxPac**, **maxPre** – the maximum values of fundamental harmonic act reactive power moving averages. The moving average window size cai in parameter 57 from 1 minute to 7 days.
- **maxdPre** – the maximum value of fundamental harmonic absent reacti moving average. As opposed to the absent reactive power instantaneo **dPre**, which is the difference between the actual and required reactive irrespective of the instantaneous condition of the controller's closed ou **maxdPre** is only evaluated if the required reactive power exceeds the : control capacity (that is the total power of all compensation banks, or s its value is determined as a difference between this control capacity an power (if the control capacity is sufficient, the **maxdPre** value is zero). average window size can be specified in parameter 57 from 1 minute to

3. Maximum temperature **maxTemp**

The temperature moving average maximum value. The moving window depth is fixed at 1 minute.

The above described recorded values can be cleared, each group separately – when clearing a value, all other values in the same groups are cleared too. Clearing values is explained in the Editing chapter further down the manual.

Table 1.2: List of Measurement Quantities – COS Branch

| abbreviation | symbol | quantity | unit |
|----------------|---------------------------------|--|---------------|
| Pac | ΠΑΧ | Instantaneous fundamental harmonic active power (Power active). | kW / MW * |
| Pre | Πρε | Instantaneous fundamental harmonic reactive power (Power reactive). | kvar / Mvar * |
| dPre | ΔΠρε | Instantaneous fundamental harmonic reactive power difference to achieve target power factor (Delta Power reactive). | kvar / Mvar * |
| Temp | °X_{or} °Φ | Instantaneous temperature (in the distribution board cabinet, at the controller). Displayed in degrees Celsius or Fahrenheit, as specified in parameter 58. | °C or °F |
| Acos | ΑΧΟΣ | Average power factor in the power system over the time specified in parameter 56 (Average cos). | — |
| mincos | νΧΟΣ | Minimum power factor in the power system achieved since last clear. The evaluation window is specified in parameter 57. | — |
| APac | ΑΠΑ Χ | Average fundamental harmonic active power in the power system over the time specified in parameter 56 (Average Power active). | kW / MW * |
| maxPac | μΠΑΧ | Maximum fundamental harmonic active power in the power system achieved since last clear. The evaluation window is specified in parameter 57 (Maximum Power active). | kW / MW * |
| APre | ΑΠρε | Average fundamental harmonic reactive power in the power system over the time specified in parameter 56 (Average Power active). | kvar / Mvar * |
| maxPre | μΠρε | Maximum fundamental harmonic reactive power in the power system achieved since last clear. The evaluation window is specified in parameter 57 (Maximum Power reactive). | kvar / Mvar * |
| maxdPre | μΔΠρ | Maximum fundamental harmonic reactive power difference to achieve target power factor in the power system achieved since last clear. The evaluation window is specified in parameter 57 (Maximum Delta Power reactive). | kvar / Mvar * |
| maxTemp | μ°X_{or} M°Φ | Maximum temperature recorded since last clear. The evaluation is based on temperature one-minute moving averages (Maximum Temperature). | °C or °F |

* ... in kW-, kvar- units as default; flashing decimal point indicates value in MW, Mvar

4.7.1.2.21.8.1.2.2 A Branch

All quantities related to current are shown in this branch. The **maxTHDI** value can be cleared manually.

Table 1.3: List of Measurement Quantities – A Branch

| abbreviation | symbol | quantity | unit |
|--------------------|---|--|----------|
| lact | $AX\tau$ | Instantaneous active current fundamental harmonic component (active). | A / kA * |
| lrea | $\rho\varepsilon A$ | Instantaneous reactive current fundamental harmonic component (reactive); L indicates inductive, C indicates capacitive polarity. | A / kA * |
| dlrea | $\delta\rho\varepsilon A$ | Instantaneous reactive current fundamental harmonic component difference to achieve the target power factor in the power system (Delta reactive). | A / kA * |
| THDI | $\tau H\delta$ | Instantaneous level of power system current's total harmonic distortion (Total Harmonic Distortion) – shows the ratio of current higher harmonic components content, up to the 19 th harmonic, to the level of fundamental harmonic. It is only evaluated if the total power system load is at least 5% of the nominal load in terms of current determined by the metering current transformer conversion primary side value (parameter 12). | % |
| 3. ÷ 19.har | $H-3$ ÷19 | Instantaneous current harmonic component level in the power system. | % |
| maxTHDI | $M\tau H\delta$ | Maximum THDI value achieved since last clear. The evaluation is based on THDI one-minute moving averages. | % |

* ... in A as default; flashing decimal point indicates value in kA

4.7.1.2.31.8.1.2.3 V Branch

This branch shows all the quantities related to voltage. They are commonly used quantities Capacitor Harmonic Load, **CHL**, factor needs further explanation – details to be found in further below.

The maximum values can be cleared manually. Clearing any of these values clears all the maximum values within this branch.

Table 1.4: List of Measurement Quantities – V Branch

| abbreviation | symbol | quantity | unit |
|-------------------------|---|--|------|
| F | Φ | Instantaneous voltage fundamental harmonic component frequency. | Hz |
| CHL | XHA | Instantaneous value of Capacitor Harmonic Load factor (Capacitor Harmonic Load). | % |
| THDU | $\tau H\delta$ | Instantaneous level of power system voltage's total harmonic distortion (Total Harmonic Distortion) – shows the ratio of current higher harmonic components content, up to the 19 th harmonic, to the level of fundamental harmonic. | % |
| 3. ÷ 19.har | $H-3$ ÷19 | Instantaneous level of harmonic component voltage in the power system. | % |
| maxCHL | MXH Λ | Maximum CHL value achieved since last clear. The evaluation is based on CHL one-minute moving averages. | % |
| maxTHDU | $M\tau H\delta$ | Maximum THDU value achieved since last clear. The evaluation is based on THDU one-minute moving averages. | % |
| 3. ÷ 19. maxharl | $MH-3$ ÷19 | Maximum value of voltage harmonic component achieved since last clear. The evaluation is based on harmonic component one-minute moving averages. | % |

4.7.1.31.8.1.3 Controller Parameters

You can view controller parameters by pressing the **P** button (parameters). First the parameter number shows momentarily and then its value does. The parameter number flashes momentarily every five seconds for better orientation.

The parameters can be divided into three main groups:

- Parameters determining controller functions. These parameters can be set to direct the control process. There are target power factor, control period, reconnection delay time, etc.
- Parameters indicating controller's current condition. This is the alarm (parameter 40), error condition (parameter 45), and control time (parameter 46). These parameters' values are set by the controller and they identify nonstandard or error conditions and monitor progress of the control process in detail.
- Total connected times recorded and numbers of connections of each compensation banks, or sections (parameters 43 and 44, respectively). These values are set by the controller and the operator can only clear them.

The parameters are organized by ordinal number in the main branch – see Figure 1.3. Some of the parameters (parameter 25 – sectional power, 26 – fixed sections, 30 – alarm setting, 40 – state of alarm, 43 – total connected times, 44 – number of sections connected) are located on side branches for easier navigation. You can switch to a side branch with selected parameters by pressing button **P** (parameters) and switch back to the main branch in the same way. Side branch parameter displayed are identified by a dash between the parameter number and value. For example: in the main branch, while showing parameter 26 (fixed sections), you will see **01 C** (section 1 is a capacitive compensation one); if you want to display conditions of the other sections, you need to switch display to the side branch by pressing button **P**; the display will change to **01-C** and now you can move up and down the branch, through all sections' values. Pressing button **P** again returns display to the main branch (the dash disappears).

Figure 1.3: Parameter Display – Structure

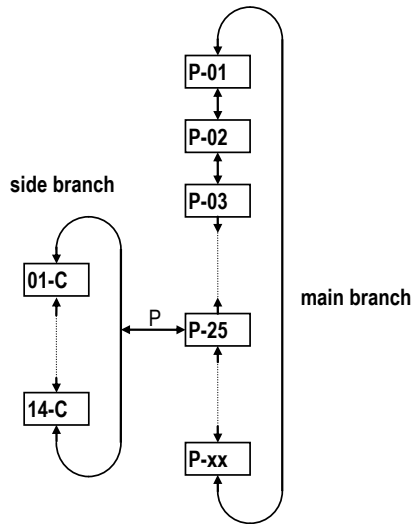

Pressing button **M** (measurement) returns to the instantaneous value display mode. The controller gets back to this mode automatically in about 30 seconds from the last press of button.

Exception: In the **Manual** mode the parameter values cannot be viewed. Instantaneous values are displayed on pressing button **P** (parameters) — see description further below.

Formatted: Bullets and Numbering

4.6.11.8.2 NOVAR 10xx Controllers

NOVAR 1005 and NOVAR 1007 controllers are equipped with 3 buttons only – instead of 4 buttons, they feature one **▶** - button.

Listing through windows is analogic; the only difference is that both instantaneous measurements and controller parameters are situated in one common main branch, one below another (

Fig. 1.4 : Instantaneous values and parameters (NOVAR 1005 / 1007)

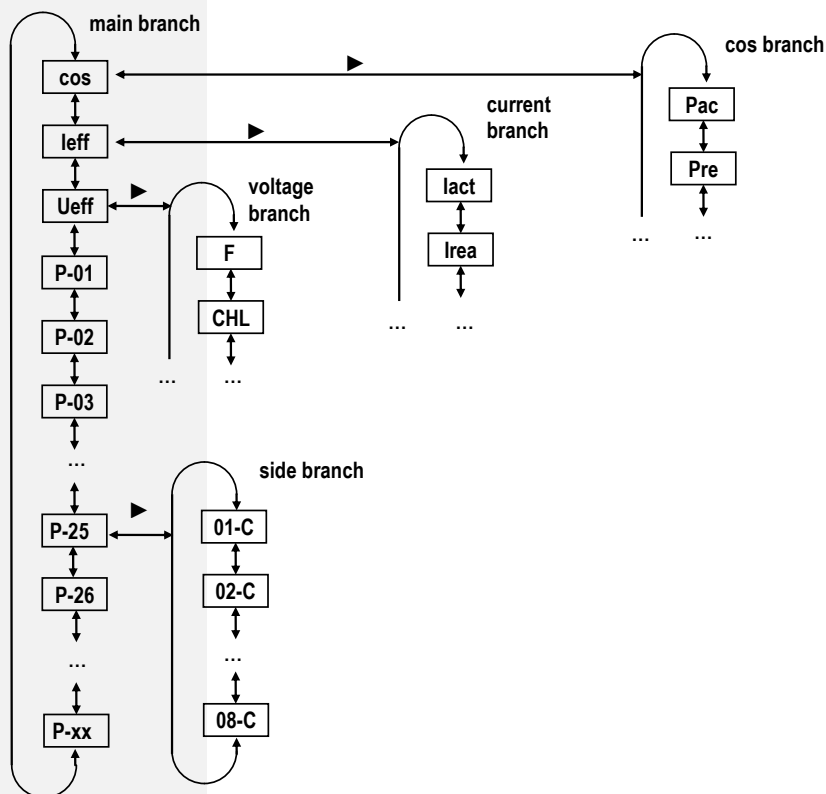

4.7.31.8.3 Test and Error Messages

In the instantaneous value display mode a test or error message pops up in place of an instantaneous power factor value in some situations. Each message is described further below in more detail. In these situations, if the value shown does not represent instantaneous power factor, the **C** flashes.

4.81.9 Indication LEDs

Besides the numeric display and adjacent LEDs, **COS**, **A**, **V**, the front panel has some other indication LEDs.

4.8.41.9.1 Output State Indications

The array of LEDs at the top right of the front panel show the current state of output relays. Each LED is assigned a number from 1 to 14, and if lit, they indicate closed contacts of the corresponding output relay.

If a LED is flashing, it means the controller wants to connect the output, but it has to wait for the delay time to elapse. The corresponding output relay contacts are open and they will be closed as soon as the reconnection delay time has elapsed.

An exception is the power-up display test to check correct operation of all display elements. In this test the display shows **TEST** and all indication LEDs come on and go out one by one. All output relays stay open while the test is running.

4.8.21.9.2 Trend Indication

These LEDs show the magnitude of deviation of the true instantaneous reactive power in the power system from optimum reactive power value which would correspond to the specified value of required power factor.

If the deviation is smaller than a half of the reactive power value of the smallest capacitor, both LEDs are dark. If the deviation is greater than a half of, but smaller than, the reactive power value of the smallest capacitor, the corresponding LED flashes — if lagging (undercompensation), the **IND** LED flashes; if leading (overcompensation), the **CAP** LED flashes. If the deviation exceeds the value of the smallest capacitor, the corresponding LED is permanently lit.

Exceptions to these LEDs' meanings are the following situations:

- measurement U and I method of connection is not defined (parameter 16)
- automatic connection configuration detection process is in progress
- automatic section power recognition process is in progress

If the method of connection is not defined, both LEDs flash; they are dark in the other two situations.

4.8.31.9.3 Indication of Manual Mode

Flashing **Manual** LED indicates that the controller is in the manual mode. The controller's automatic control function is disabled.

If this LED is dark and display is in the **Measurement** mode, the controller is in its standard control mode or it is carrying out automatic connection configuration detection process or automatic section power recognition process.

4.8.41.9.4 Indication of Backfeed (Power Export)

If the controller knows of the method of connection (measurement voltage and current), that is if the automatic connection configuration detection process has been completed successfully or the method of connection has been entered manually, the **Export** LED indicates the power transmission direction. If it is dark, the power is flowing from the assumed power supply to the appliance. If the LED is lit, the power is flowing in the opposite direction.

4.8.51.9.5 Alarm Indication

An **Alarm** relay can be used for non-standard events signalling. This relay's operation can be set up as described further below (parameter 30). At NOVAR 10xx controllers that haven't dedicated alarm relay it is necessary to select and set alarm relay function first (parameter 26).

The **Alarm** LED indicates this relay's condition, that is if the **Alarm** relay's output contact is closed, the LED flashes.

2. Installation

2.1 Physical

The instrument is built in a plastic box to be installed in a distribution board panel. The in position must be fixed with locks.

Natural air circulation should be provided inside the distribution board cabinet, and in the neighbourhood, especially underneath the instrument, no other instrumentation that is so should be installed or the temperature value measured may be false.

2.2 Connection

To connect the controller there are connectors with screw-on terminals in the back wall. on these connectors is illustrated in Figures 2.1 and 2.2.

Examples of controller wiring are shown in a separate chapter.

Fig. 2.1 : NOVAR1114 controller – connectors

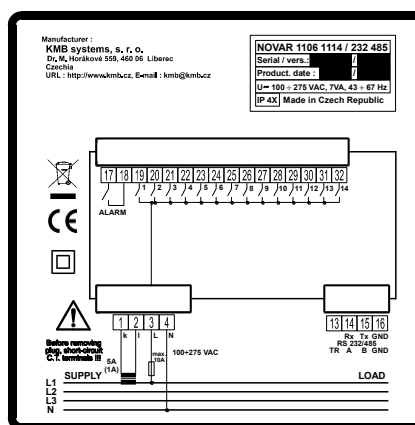

Maximum cross section area of connection wires is 2.5 square millimetres.

2.2.1 Power Supply

2.2.1.1 Standard Version Controllers

The controller requires supply voltage in the range as declared in technical specifications operation.

The supply voltage connects to terminals 3 (**L**) and 4 (**N**). In case of DC supply voltage the connection is free. Power supply voltage needs to be externally protected (see chapter 1 below).

The 12xx line controllers have power supply terminals 3 (**L**) and 4 (**N**) internally connecte 5 (**L**) and 6 (**N**) which can be used to connect the power supply voltage to measurement (terminals 7 – **L** and 9 – **N/L**).

Power supply terminal 3 (**L**) is internally connected to the common pole of output relays. necessary to dimension the power supply protection in consideration of output contactors well.

Fig. 2.2 : NOVAR1214 Controller – Connectors

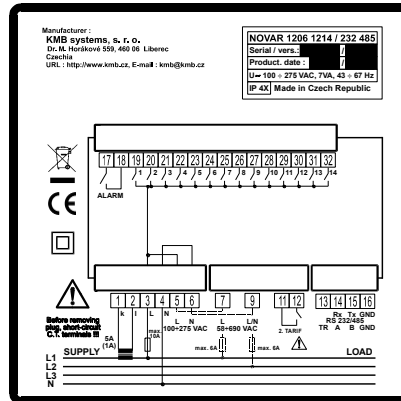

2.2.1.2 "/S400" Version Controllers

Controllers of the "/S400" version can be supplied with higher voltage – up to 500 V, either AC or DC. The power demand is the same as those of standard version.

The supply voltage connects to terminals 3 (**L1**) and 5 (**L2/N**). In case of DC supply voltage the polarity of connection is generally free, but for maximum electromagnetic compatibility grounded pole should be connected to the terminal 5 (**L2/N**); see connection examples below.

Power supply voltage need to be externally protected (see following chapter).

Despite of standard version, power supply terminal 3 (**L**) is **not** internally connected to the common pole of output relays. Terminals 4 and 6 are not used.

Fig. 2.3 : NOVAR1114/S400 Controller – Connectors

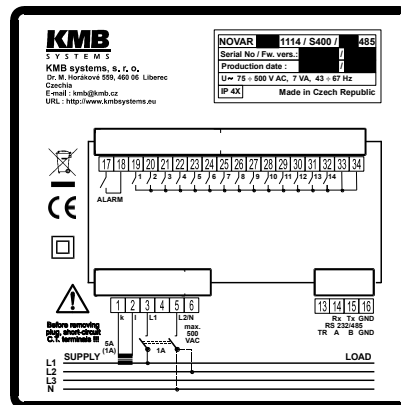

Formatted: Bullets and Numbering

2.2.1.3 NOVAR 1005 / 1007 Controllers

The supply voltage connects to terminals 4 (**L1**) and 3 (**N**). In case of DC supply voltage the polarity of connection is free. Power supply voltage need to be externally protected (see chapter **Protection** below).

Power supply terminal 4 (**L1**) is internally connected to the common pole of output relays. It is necessary to dimension the power supply protection in consideration of output contactors' power as well.

Fig. 2.4 : NOVAR 1007 Controller – Connector

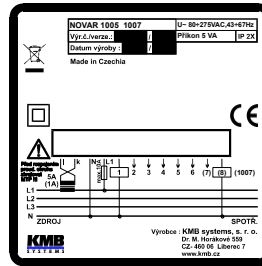

2.2.1.4 Protection

Article 6.12.2.1 in the EN 61010-1 standard requires that instrument must have a disconnector in the power supply circuit (a switch — see installation diagram). It must be located at the immediate proximity and easily accessible by the operator. The disconnecting device must function as such. A circuit breaker for nominal current of 10 amp makes a suitable disconnecting function and working positions, however, must be clearly marked (symbols “0” for power on in accordance with EN 61010-1).

Since the controller’s inbuilt power supply is of pulse design, it draws momentary peak current powerup which is in order of magnitude of amperes. This fact needs to be kept in mind with the primary protection devices.

2.2.2 Measurement Voltage

2.2.2.1 11xx and 10xx Line Controllers

The power supply voltage is used as measurement voltage in 11xx line controllers and it is necessary (or possible) to connect measurement voltage independently.

2.2.2.2 12xx Line Controllers

The 12xx Line Controllers feature a general-purpose, galvanic-insulated voltage measurement allows to connect measurement voltage in the range from 45 to 760 V AC at the frequency to 67 Hz of either phase or line voltage. In basic connection phase L1 goes to terminal **L**, neutral wire to terminal **N/L** (9).

The measurement voltage must be protected externally. If the measurement voltage is independent power supply voltage, they can share a circuit breaker. Otherwise each voltage branch must be protected with fuses or circuit breakers of nominal value 1 to 6 A.

If the measurement voltage is connected via a metering voltage transformer, you have to set transformer turns ratio in instrument setup (parameter 17 – see further below) for correct measurement values displayed.

2.2.3 Measurement Current

Metering current transformer (CT) outputs connect to terminals 1 (**k**) and 2 (**I**). At 10xx line connection polarity is opposite : terminal 1 is **I** and terminal 2 is **k**.

A metering current transformer of nominal output current 5 or 1 A can be used – the metering transformer’s ratio must be entered when setting up the instrument for proper measured display (parameters 12, 13 – see further below). At NOVAR-11xx models, the connector has a screw lock to prevent accidental pull-out.

2.2.4 Error Indication

2.2.4.1 NOVAR 11xx / 12xx / 13xx Controllers

The instrument has an auxiliary Alarm relay to indicate nonstandard conditions. This relay's contact goes to terminals 17 and 18.

2.2.4.2 NOVAR 10xx Controllers

Non-standard events can be signalled by one of last two output relays (if they are not used for control). It is necessary to set such relay function properly, see parameter 26.

2.2.5 Output Relays

The instrument has 6, 8 or 14 output relays (depending on controller model). The relays' contacts go to terminals 19 through 32 (or 5 through 12 at NOVAR-10xx models).

The relays' output contacts are internally wired with varistors.

2.2.5.1 Standard Version Controllers

The relays' common contacts are internally connected to power supply terminal **L** (No. 3; or No. 4 at NOVAR-10xx models). When an output relay contact closes, power supply voltage appears at the corresponding output terminal.

2.2.5.2 "S400" Version Controllers

Despite of standard version, the relays' common contacts are connected to additional terminals 33, 34.

In case of DC voltage for supplying of contactors, installation of suppression 2A/600V diodes directly at contactors' coils is strongly recommended. Furthermore, note lower maximum current load of the controller outputs at such case (see technical parameters table).

In installation there may be a need to test function of each compensation section by manual connection and disconnection — this can be done in the **Manual** mode or using *manual intervention in control process* (see further below).

2.2.6 Second Metering Rate, External Alarm

In some situations it may be suitable to operate the controller with two different settings, for example depending on load characteristics in different daily or weekly zones. To select the setting desired, there is the second metering rate input.

WARNING !!! This input is not galvanically insulated from the controller's internal circuitry and its terminals constitute exposure to hazardous voltage against the ground potential! It is therefore necessary for the relay, switch or optocoupler, driving the input, to be insulated (no external voltage) and to be located as close to the controller as possible (optimally in the same cabinet) to minimize the lead length (maximum about 2 to 3 metres). The input is connected to terminals 11 and 12. The input's internal power supply voltage is about 30 V DC, switching current about 5 mA.

If the second metering rate active device is a transistor (NPN) or optocoupler, it is necessary to observe the connection polarity – transistor or optocoupler collector to go to terminal + (11) and emitter to terminal – (12).

When the input is open, the controller operates with the basic metering rate setting, when it is closed (if the second metering rate function is enabled – see further below), it operates with the second metering rate setting.

If second metering rate function is switched off, the second metering rate input can be used for external alarm signal – see description of parameters 30, 40.

Only 12xx and 13xx line controllers feature the second metering rate selection input.

2.2.7 Communication Interface

The controllers can be equipped with galvanically insulated communication interface in accordance with RS-232 or RS-485 specification for remote setup and control process monitoring.

2.2.7.1 RS-232 Communication Interface

The communication link uses an additional four-pole connector in the back panel (terminal 16). The signals are assigned as shown in Tab. 2.1.

The communication interface complies with CCITT V.28 (RS-232) recommendations, that is with minimum internal impedance load 3 k Ω . Signals in accordance with CCITT V.24 are 102 (common wire), 103 (transmission data) and 104 (reception data).

The interface can be used to connect one controller to a remote computer. Communication maximum length is about 30 meters (shielded cable, such as 3 x AWG24, recommended).

Table 2.1: communication line signal configuration

| signal | pin |
|----------------------------------|-----|
| RxD, receive data | 14 |
| TxD, transmit data | 15 |
| GND/C, communication line ground | 16 |

2.2.7.2 RS-485 Communication Interface

Signal-to-pin configuration for RS-485 type line is shown in Tab. 2.2.

Table 2.2: communication line signal configuration

| signal | terminal |
|--------|----------|
| TR | 13 |
| DATA A | 14 |
| DATA B | 15 |
| GND/C | 16 |

The interface allows connecting up to 32 instruments at a distance up to about 1 kilometer. Recommended cable is shielded twisted metallic double pair.

RS-485 line requires impedance termination of the final nodes by installing terminating resistors. For communication distances of a few tens of metres and longer. Terminating resistors matching cable's wave impedance are connected between terminals 14 and 15 (DATA A and DATA B). The instrument has a built-in terminating resistor of 330 ohms. It is connected between DATA B (terminal 15) and TR-terminal (13) inside the instrument. To install the resistor, simply connect terminals DATA A (14) and TR (13).

If the communication cable is hundreds of meters long and in environments with electron noise it is suitable to use shielded cable. The shielding connects to terminal 16 (GND/C) (protection earth) wire at one end of the cable.

3. Putting in Operation

3.1 First Use

The controller comes preset to default values as shown in Table 4.1.

On powerup, display test runs first. The display momentarily shows

- type of controller (e.g. **N214**)
- firmware version (e.g. **1.2**)
- type of measurement voltage set (**Y=ΛN** or **Y=ΛΛ**)
- metering current transformer secondary side nominal value set (**I=5A** or **I=1A**)

If the measurement voltage connection is correct, the automatic connection configuration detection process starts.

If no measurement voltage is detected, **Y=0** will flash on the display.

3.2 Automatic Connection Configuration Detection Process

The controller's default measurement voltage and current connection parameters are set as follows:

- type of measurement voltage set to phase voltage ("LN", parameter 15)
- method of connection of U and I not defined (parameter 16)
- compensation system nominal voltage **U_{NOM}** set to 230 V (parameter 18)

If the method of connection is not defined, the controller cannot evaluate instantaneous power factor and this condition is indicated by both trend LEDs flashing simultaneously. In such an event, the controller carries out automatic connection configuration detection process.

For the controller to be able to carry out this automatic connection configuration detection process, the following conditions must be met:

- controller operation is not disabled (i.e. the **Manual** LED is dark)
- controller is in the control mode, i.e. the numeric display mode is **Measurement**
- measurement voltage of the minimum value required is connected

If meeting the three above conditions, the controller starts the automatic connection configuration detection process.

The process may have up to seven steps. The controller makes four measuring attempts in each step in which it consecutively connects and disconnects sections 1 through 4. It, at the same time, assumes that power factor capacitors are connected to at least two of the sections (if any choke connected to sections 1 through 4, detection process fails). The two following messages are shown, one after another, in each measurement attempt on the numerical display:

1. step number in format **АПv** (**A**utomatic **P**hase detection, nn... attempt)
2. attempt result, e.g. **А1-0** (see Table 4.4 for connection methods)

If the controller measures identical values repeatedly in each attempt, it considers the code detected and quits carrying out further steps. If the measurement results are different from one in a particular step, the controller carries out another measurement step.

The following conditions must be met for successful automatic connection configuration detection process:

- type of measurement voltage is set correctly (phase, "LN" or line, "LL" – parameter 16)
- at least two power factor capacitors are connected to sections 1 through 4 and a power factor choke is connected to these sections

The controller measures the measurement voltage value for the whole of the automatic connection configuration detection process. It evaluates this voltage's average value at the end of the process and selects the compensation system nominal voltage U_{NOM} (parameter 18) as the nearest to the following choice of nominal voltages.

Table 3.1: choice of nominal voltages

| | | | | | |
|------|-------|-------|-------|-------|-------|
| 58 V | 100 V | 230 V | 400 V | 500 V | 690 V |
|------|-------|-------|-------|-------|-------|

Type of connection detected is shown on the numeric display for a moment after successful completion of the automatic connection configuration detection process, the selected U_{NC} voltage, the true power factor value in the power system, and thereafter the instrument's control process or it starts the automatic section power recognition process (see further text).

If the automatic connection configuration detection process is not completed successfully, the numeric display shows flashing **П=0**. It is, in such a case, necessary to enter the type of connection manually or to re-enter ---- (= not defined) in editing parameter 16 and thus restart the automatic connection configuration detection process. Otherwise the controller changes over to a wait mode and it repeats the automatic connection configuration detection process in 15 minutes automatically.

If the actual nominal voltage in the compensation system differs from the value selected in parameter 18 in the automatic connection configuration detection process, the parameter is automatically corrected to its actual value when the process has finished.

The automatic connection configuration detection process can be interrupted at any time by changing the numeric display mode to **Parameters**. The automatic connection configuration detection process will start again from scratch on return to instantaneous value display mode.

3.3 Automatic Section Power Recognition Process

The controllers come with enabled function of automatic section power recognition process (parameter 20 set to A) as default setting. The controller starts the automatic section recognition process on powerup (connection of power supply voltage) with this setting, provided none of the compensation system parameters (parameter 25) has a valid power value; this happens if a new controller is installed for the first time after its initialization). The process can also be started without interrupting the power supply connection, by editing parameter 20 to value 1 or by controller initialization (see further text).

For the controller to be able to start the automatic section power recognition process, the following conditions must be met:

- controller automatic operation is not disabled (i.e. the **Manual** LED is dark)
- controller is in control mode, i.e. the numeric display mode is **Measurement**
- measurement voltage, at minimum value required, is connected
- connection mode of measurement U and I is defined (parameter 16)

If these conditions are met, the controller starts the automatic section power recognition process.

The process may have three or six steps. The controller consecutively connects and disconnects each output in each step. While doing that, it measures the effect of connection and disconnection on total reactive power in the power system. From the values measured the power of each section is determined.

The following messages are shown one after another in each measurement attempt on the numeric display:

1. Step number in format **AX-v** (n... step number).
2. Sectional power measured in kvars; the **nominal** power value of the section under measurement is displayed, that is the value that corresponds to nominal voltage U_{NOM} of the compensation system as specified in parameter 18. If the metering current transformer turns ratio has been entered (parameters 12 and 13), or, if measuring voltage via a metering voltage transformer, the voltage transformer's turns ratio as well (in parameter 17), sectional power in the power system is shown (that is at the metering current transformer primary side, or metering voltage transformer primary side). If the metering current transformer primary side (parameter 12), or metering voltage transformer primary side (parameter 17) is not defined, sectional power in the metering current transformer's, or the metering voltage transformer's, secondary side is shown.

If the controller does not succeed in determining a section's value, it does not show it. This condition occurs if reactive power value in the power system fluctuates considerably due to changes in load.

After carrying out three steps, evaluation is carried out. If each measurement in the steps carried out provides sufficiently stable results, the automatic section power recognition process is completed. Otherwise the controller carries out three more steps.

A requirement for successful automatic section power recognition process is sufficiently stable condition of the power system – while connecting or disconnecting a section, the reactive load power must not change by a value which is comparable with, or even greater than, the reactive power value of the section under test. Otherwise the measurement result is unsuccessful. As a rule of thumb, the section values are recognized the more precisely, the lower the load is in the power system.

On successful completion of automatic section power recognition process, the controller checks whether at least one capacitive section has been detected and, if so, it starts control. Otherwise the controller goes to the waiting mode and after 15 minutes it starts the automatic section power recognition process again.

Each section value recognized can be checked in the side branch of parameter 25. A positive power value means a capacitive section, negative value means inductive section. If the value could not be recognized, “———” is shown. Each value recognized can be edited manually.

If the automatic section power recognition process can not be completed successfully or none of the sections recognized is capacitive, flashing **X=0** is shown on the numeric display and the **Alarm**

signal is activated at the same time. In such an event, it is necessary to enter each section manually (see description further below) or by editing parameter 20 enter value **A** (= call automatic section recognition power process) or **1** and thus force another start of the automatic section power recognition process.

The automatic section power recognition process can be stopped any time by switching the mode to **Parameters**. On return to the instantaneous value display mode the automatic section recognition process will be started over again.

4. Operation

4.1 Setup

To achieve optimum compensation in accordance with character of the load controlled, the controller has a number of parameters that govern its operation. Table 4.1 shows a list of the parameters. The following chapters describe each parameter, its meaning and how it can be edited.

4.1.1 Editing Parameters and Clearing Recorded Measurement Values

4.1.1.1 Parameter Editing

The controller's parameters are set to default values, which are shown in Table 4.1, when shipped.

To achieve optimum compensation results, it is sometime necessary to change some of the values in correspondence with particular requirements; in the other situations it is at least necessary to enter the measurement voltage type (phase or line) and current transformer turns ratio, within installation of the instrument.

If parameter edit is enabled (see next chapter), you should proceed as follows:

1. Switch controller to parameter display mode by pressing button **P** (for NOVAR-11xx models only).
2. Find parameter you want to edit by pressing the **▲** , **▼** buttons repeatedly.
3. Press button **P** (**▶**) and hold it down until the display starts flashing.
4. Release button **P** (**▶**) and set the value desired with the **▲** , **▼** buttons. Some values can be incremented or decremented continuously by holding down the **▲** or **▼** button.
5. When the value desired is displayed, press button **P** (**▶**). The value will be saved in the controller's memory, the display stops flashing and editing is thus complete.

4.1.1.2 Clearing Recorded Measurement Values

Recorded measurement values specified in Chapter 1 can be cleared in an analogous way:

1. Switch the controller to the measurement value display mode (for NOVAR-11xx models only) and scroll to the value you want to clear using the **▲** , **▼** and **M** (or **▲** , **▼** and **▶** for NOVAR-10xx models) buttons.
2. Press the **M** (**▶**) button and hold it pressed until the displayed value starts flashing.
3. Release the **M** (**▶**) button and by pressing the **▲** or **▼** button change display to show **XΛp** (= clear). The following press of the **M** (**▶**) button will clear the value.

Clearing a value clears all the other values in its group and starts over their evaluation.

4.1.1.3 Enable / Disable Parameter Edit

When shipped, the controller has the Parameter Edit feature enabled, that means the parameters can be edited freely on power supply voltage connection as desired. After being put in operation, Parameter Edit can be disabled to protect the controller against unauthorized changes to its mode of operation.

To see if Parameter Edit is disabled or enabled, check parameter 00. It can contain the following:

Ed=0 edit disabled

Ed=1 edit enabled – parameters can be edited, recorded measurement values can be cleared

If Parameter Edit is locked, you can unlock it using the following procedure, which is similar to the controller's parameters:

1. Switch controller to parameter display mode by pressing button **P** to display parameter list with buttons **▼**, **▲** to parameter 00 for NOVAR-10xx models) - **Ed=0** is correct (controller must not be in the **Manual** mode).
2. Press button **P** (**▶**) and hold it down until the last character on the display starts to flash. A digit between 0 and 9 will be shown on the last digit position. As an example you can see 5 is displayed so the display shows **Ed=5** with the **5** flashing.
3. Press the following sequence: **▼**, **▲**, **▲**, **▼**. If **5** was shown as the last displayed digit, the display would change to **4 - 5 - 6 - 5**, so the same value is shown at the end as at the beginning.
4. Press button **P** (**▶**). The display will show **Ed=1**, indicating correct password entered and Parameter Edit mode enabled while clearing recorded measurement values.

The digit shown while entering the unlocking keypress sequence is randomly generated by the controller and it is not important for its correctness (it is there only to confuse). Only the sequence of buttons pressed is important.

Parameter Edit mode is enabled until it gets disabled by the operator. Parameter Edit mode disabled condition is retained in the instrument even on power off.

Parameter Edit can be disabled in a way analogous to enabling it but you press buttons in the correct unlocking keypress sequence.

4.1.2 Parameter 01/07 – Target Power Factor

The value of target power factor for metering rate 1 (parameter 01) or metering rate 2 (parameter 07) can be specified in the range from 0.80 lag to 0.80 lead.

If a more precise setting is required around power factor equal to 1.00, you can specify the phase shift angle from +10 to –10 degrees instead of the power factor value. The phase shift angle is scrolled to by pressing the **▲** key while editing the parameter until the phase shift angle required is displayed, which is marked with a degree symbol, for example **10°** means +10 degrees.

If the parameter is specified as a phase shift angle in degrees, the bandwidth on high load is displayed in degrees too (see parameter 04/10 further below).

4.1.3 Parameter 02/08 – Undercompensation Control Time

The value for metering rate 1 (parameter 02) or metering rate 2 (parameter 08) can be specified in the range from 5 seconds to 20 minutes: 0.05 - 0.10 - 0.15 - 0.20 - 0.30 - 0.45 - 1.0 - 1.30 - 2.0 - 5.0 - 7.0 - 10.0 - 15.0 - 20.0 (the number before decimal point specifies minutes, that after decimal point specifies seconds). The value specified determines the frequency of control interval under the following conditions:

- instantaneous power factor is more inductive than the value required – undercompensated
- the difference between reactive power instantaneous value in the power system and optimum value, which corresponds to the target power factor setting (= control interval) is just equal to the smallest capacitive section current (C/k_{MIN})

If the parameter value is set to say 3.0 and the above mentioned conditions are met in the power system, the controller calculates optimum compensation and carries out control intervention every 3 minutes.

The time mentioned gets shorter in proportion to the instantaneous control deviation. If control time without preceding character "L" is set, it gets shorter as square of control deviation over the smallest capacitive section value (C/k_{MIN}). If the control time with preceding character "L" is specified, it gets shorter in proportion to this ratio ("L" = Linear, causes slower response to large deviations). Rising control deviation can decrease this value to the minimum control time of 5 seconds.

On the contrary, if the control deviation is smaller than the smallest capacitive section current (C/k_{MIN}), control time gets twice as long. If the control deviation falls further under half of the smallest capacitive section current value (C/k_{MIN}), no control interventions take place.

4.1.4 Parameter 03/09 – Overcompensation Control Time

The value for metering rate 1 (parameter 03) or for metering rate 2 (parameter 9) determines the frequency of control interventions, very much like in parameter 02/08 described above. There is a difference though: it only applies if the instantaneous power factor is more capacitive than that required, that is it is overcompensated.

The control time operation in proportion to control deviation magnitude is the same as with parameter 02/08 described above.

4.1.5 Parameter 04/10 – Control Bandwidth on High Loads

Using this parameter you can specify the control bandwidth on high loads (see Figure 4.1). The value entered specifies the range of reactive power in the C zone which constitutes condition considered as compensated, making the controller stop control interventions.

Figure 4.1: Standard Control Bandwidth

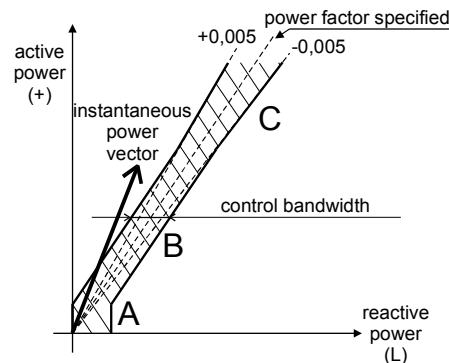

On low loads (zone A) and on medium loads (zone B), the control bandwidth is constant and corresponds to the C/k_{min} value – the band follows the power factor slope specified at width $\pm (C/k_{MIN})/2$. On high loads (zone C) the bandwidth increases so its limits correspond to adjustable deviation from the target power factor. The standard bandwidth value in this zone is 0.010 or ± 0.005 – this condition is shown in Figure 4.1. If thus, for example, the target power factor is specified as 0.98, reactive power corresponding to power factor from 0.975 to 0.985 will be considered compensated condition in zone C.

Table 4.1: NOVAR10xx/11xx/12xx Controller Parameters

| # | name | range | step | default | comment |
|---------|---|---|-------|---|---|
| 0 | parameter edit enable/disable | 0 / 1 | — | 1 | see Enable / Disable Parameter Editing |
| 1 | target power factor (metering rate 1) | 0.80 L ÷ 0.80 C | 0.01 | 0.98 L | |
| 2 | control time when undercompensated (metering rate 1) | 5 sec ÷ 20 min | — | 3 min | No "L": control time reduction by squared proportion "L": linear control time reduction. |
| 3 | control time when overcompensated (metering rate 1) | 5 sec ÷ 20 min | — | 30 sec | No "L": control time reduction by squared proportion "L": linear control time reduction |
| 4 | control bandwidth | 0.000 ÷ 0.040 | 0.005 | 0.010 | |
| 6 | metering rate 2 enable/disable | 0 – 1 – E | — | 0 | |
| 7 ÷ 10 | like parameters 1 ÷ 4, but for metering rate 2 | the same as parameters 1 ÷ 4 | — | — | not shown unless metering rate 2 is enabled |
| 12 | metering current transformer primary side nominal value | 5 ÷ 9950 A | 5 | none | |
| 13 | metering current transformer secondary side nominal value | 1 A ÷ 5 A | — | 5 | |
| 14 | reconnection delay time | 5 sec ÷ 20 min | — | 20 sec | |
| 15 | measurement voltage type – phase-neutral or phase-phase | LN (phase) – LL (line) | — | LN | This parameter's correct setting is essential for automatic connection configuration detection process. |
| 16 | method of connection of U and I | 6 combinations | — | none | see parameter description |
| 17 | VT turns ratio | no VT or 10 ÷ 5000 | — | --- (no VT) | VT nominal primary to secondary voltage ratio |
| 18 | compensation system nominal voltage U_{NOM} | 50 ÷ 750 V x VT turns ratio | — | 230 / 400 V | controller establishes this value within automatic connection configuration detection process |
| 20 | automatic section power recognition process | A (auto) – 0 (no) – 1 (yes) | — | A | |
| 21 | switching program, linear switching mode | 12 typical combinations or "1" | — | none | 0 means individual section setting. Not shown if automatic section power recognition process is enabled. |
| 22 | smallest capacitor nominal power (C/k value calculated for metering current transformer primary side) | (0.007 ÷ 1.3 kvar) x CT ratio x VT ratio | 0.001 | none | Value corresponds to U_{NOM} specified (parameter 18) Not shown if automatic section recognition is enabled. |
| 23 | number of capacitors | 1 ÷ 14 | — | 6 / 8 / 14 | Not shown if automatic section power recognition process is enabled. |
| 25 | sectional nominal power | (0.001 ÷ 5.5 kvar) x CT ratio x VT ratio | 0.001 | none | Value corresponds to U_{NOM} specified (parameter 18) positive for capacitive sections (lead), negative for chokes (lag) |
| 26 | fixed sections | regulated or 0 / 1 / F / H / A | — | all regulated | „F“ / „H“ / „A“ for 2 highest sections only „A“ for NOVAR 1005 / 1007 only |
| 27 | power factor limit for compensation by choke | 0.80 lag to 0.80 lead | 0.01 | none | No compensation by chokes takes place unless this parameter is specified. |
| 30 | alarm setting | 0 / indication only / actuation only / indication and actuation | — | indication and actuation from undercurrent, voltage signal absence or section error | 1... undercurrent 8... CHL > 2... overcurrent 9... compensation error 3... loss of voltage 4... undervoltage 10... export 5... overvoltage 11... no. of connections > 6... THDI > 7... THDU > 12... section error 13... overheated 14... external alarm |
| 31 ÷ 37 | alarm thresholds: undervoltage, overvoltage, THDI, THDU, CHL, number of connections and temperature | — | — | — | Ranges and units as in Table 4.7 not displayed if the alarm not set up |
| 40 | alarm instantaneous condition | | | | Indicates current state of alarm. |

| | | | | | |
|----|---|--------------------------|------|------------|--|
| 43 | section connection time (in thousands of hours) | | | | display range 0.001 to 130 |
| 44 | number of section connections (in thousands) | | | | display range 0.001 to 9999 |
| 45 | instrument failure condition | | | | |
| 46 | instantaneous condition of control time | | | | time until next control intervention in seconds |
| 50 | instrument address | 1 ÷ 255 | 1 | 1 | |
| 51 | communication rate | 600 ÷ 9,600 Bd | — | 9,600 | |
| 52 | communication protocol | KMB(P0) / Modbus-RTU(P1) | — | KMB(P0) | |
| 55 | power system frequency | A (auto) – 50 Hz – 60 Hz | — | A (auto) | |
| 56 | average value evaluation moving window size | 1 minute ÷ 7 days | — | 7 days | applies to average values of AcoS, APac, APre |
| 57 | minimum and maximum value evaluation moving window size | 1 minutes ÷ 7 days | — | 15 minutes | applies to these minimum and maximum values: mincos, maxPac, maxPre, maxdPre |
| 58 | Celsius/Fahrenheit temperature display mode | °C – °F | — | °C | |
| 59 | cooling enable threshold | +10 ÷ +60 °C | 1 °C | +40 °C | not displayed if cooling output not specified |
| 60 | heating enable threshold | -30 ÷ +10 °C | 1 °C | -5 °C | not displayed if heating output not specified |

The control bandwidth can be increased to 0.040 or decreased to 0.000 on high loads. Control bandwidth increase may especially be useful in systems with large control range – avoiding uselessly precise control on high loads reduces the number of control interventions which results in longer contactor service life. If the parameter values is decreased to 0, the control bandwidth corresponds to value C/k_{min} (constant, not widening).

Note: On low loads, the control bandwidth is “bent” (zone A) to prevent undesired overcompensation (the illustration is a simplification).

If the target power factor (parameter 01/07) is specified in degrees as phase shift angle, the bandwidth on high loads is also displayed in degrees.

4.1.6 Parameter 06 – Metering Rate 2 Operation

The NOVAR controllers feature two sets of the above described control parameters.

Parameter 6 decides if the control process uses the first set of basic control parameters, 1 through 4, only or if, under certain circumstances, the second set of parameters, 7 through 10 (metering rate 2) is used as well.

By default parameter 6 is set to **0** and only parameters 1 through 4 of the parameters described above are applied; parameters 7 through 10 are not significant in such an event, so they are not shown.

NOVAR1206/1214 controllers allow changing the above described basic control parameters while compensation is in progress, triggered by external signal (relay contact). They have a metering rate 2 request input for this operation, to which an insulated contact or optocoupler can be connected. If you set the parameter to **1**, the controller will start evaluating metering rate 2 requests and, depending on the input's instantaneous condition, use parameters 1 through 4 or 7 through 10.

The decimal point after the last character then indicates whether metering rate 2 request is active. If it is dark, metering rate 2 request is not active and only parameters for metering rate 1 apply. On the contrary, lit decimal point indicates active metering rate 2 request and the controller uses parameters specified for metering rate 2.

The metering rate 2 function can further be set to value **E**. In this event the second set of parameters is used for active power export, that is if active power flows from appliance to

4.1.7 Parameters 12,13 – Metering Current Transformer (CT) Ratio

You can specify metering current transformer nominal primary value in amperes using parameter 12. The value range is from 5 to 9950.

This parameter (12) is not specified (---- shown) by default. With this setting, all values that are current- or power- related, that is measured values of instantaneous effective, active and reactive currents and power, and further the C/k_{MIN} value (parameter 22) and power in each section (parameter 25), are shown in the magnitude to which they are transformed at the metering current transformer secondary side. The parameter's value specified does not affect the controller's control logic, it only affects displayed values that are related to current or power. Therefore the value must be specified later, after the automatic section power recognition process, without having to start the process again.

Parameter 13 selects metering current transformer nominal secondary current. You can select 5A and 1A. **Warning!!! Unlike parameter 12, this parameter must be set correctly for proper operation!** The controller determines whether the current input is overloaded every 10 seconds using parameter 13 and instantaneous current value. The controller may stop operation undesirably if the current is too high. Contrariwise, this operation disablement will not work when it should (see description of parameter 13 alarm from overcurrent).

Parameter 13 setting will be kept even on controller *initialization* (see description further below).

4.1.8 Parameter 14 – Reconnection Delay Time

It is used to ensure sufficient discharge of a capacitive section prior to reconnection. It can be set in a range from 5 seconds to 20 minutes to one of the values 0.05 - 0.10 - 0.15 - 0.20 - 0.30 - 0.45 - 0.60 - 0.75 - 1.00 - 1.50 - 2.00 - 3.00 - 4.00 - 5.00 - 7.00 - 10.00 - 15.00 - 20.00. The format is the same as in parameters 2 and 3.

4.1.9 Parameters 15, 16 – Type of Measurement Voltage and Connection Configuration

Parameter 15 determines if the measurement voltage connected is phase (phase-neutral connection, default value) or line (phase-phase, $Y=\Delta\Delta$). If the measurement voltage is connected to the supply transformer's side which is opposite to measurement current connection, the connection configuration value must be set in accordance with transformer type – see description in chapter further below.

Connection configuration parameter must definitely be set correctly in installation, otherwise the automatic connection configuration detection process is assumed to take place. Otherwise the factor measured will be evaluated with errors!

If the parameter value is specified as phase voltage ($Y=\Delta N$), the controller also presets the compensation system's nominal voltage value U_{NOM} (parameter 18) to 230 V. If the parameter is specified as line voltage ($Y=\Delta\Delta$), the U_{NOM} (parameter 18) is preset to 400 V.

The connection configuration parameter (15) value set will be kept even on controller *init* (see description further below).

Parameter 16 determines the method of measurement voltage connection with respect to measurement current, that is between which phases or phase and neutral wire the measurement voltage is connected. It is assumed that the metering current transformer is in phase 1 orientation (terminals k, l) corresponds to real orientation supply → appliance. The measurement voltage connection is specified as one of six combinations shown in Table 4.2.

Table 4.2: Measurement voltage connection

| phase measurement voltage - $Y=\Delta N$ | | line measurement voltage - $Y=\Delta\Delta$ | |
|---|--------------|---|---------------------|
| # | connection | # | connection |
| 1 | $\Delta 1-0$ | 1 | $\Delta 1-\Delta 2$ |
| 2 | $\Delta 2-0$ | 2 | $\Delta 2-\Delta 3$ |
| 3 | $\Delta 3-0$ | 3 | $\Delta 3-\Delta 1$ |
| 4 | $0-\Delta 1$ | 4 | $\Delta 2-\Delta 1$ |
| 5 | $0-\Delta 2$ | 5 | $\Delta 3-\Delta 2$ |
| 6 | $0-\Delta 3$ | 6 | $\Delta 1-\Delta 3$ |

Notes:

- It is assumed that the metering current transformer is in phase 1 and its orientation (terminals k, l) corresponds to real orientation supply → appliance.
- The method of connection is shown as x-y where x represents the phase connected to controller's terminal **L** and y represents the phase connected to controller's terminal **N/L** (0 represents the neutral wire).

If the method of connection value is entered as not specified (---- value), the automatic connection configuration detection process is started, with exception of case when *linear switching mode* (see parameter 21) is set. In such case the process is not started and it is necessary to set the method of connection manually.

If the type of connection (phase or line, parameter 15) is changed, the method of connection (parameter 16) is automatically set to the unspecified value.

4.1.9.1 Setting Type of Connection Configuration if Measuring at Power Supply Transformer's Opposite Sides

If the measurement current signal is from the power supply transformer's side which is opposite to measurement voltage signal side, the transformer phase angle is conclusive for correct parameter 15 setting. This value specifies the angle between voltage vectors of corresponding phases at primary and secondary sides. The transformer phase angle can be in the range from 0 to 11, corresponding to phase angles from 0 to 330 degrees (in steps of thirty degrees).

Provided the measurement voltage signal is connected **in accordance** with the type of transformer (that is phase measurement voltage is connected to controller with wye, or star, connection or line measurement voltage with delta connection), it is necessary to set **phase** type of connection with **even** transformer phase angle value and **line** type of connection with **odd** transformer phase angle value.

If the measurement voltage signal is connected **in disaccordance** with the type of transformer, the opposite rule applies: **line** connection with **even** transformer phase angle or **phase** connection with **odd** transformer phase angle.

Determining parameter 15 explained in practical examples:

Example 1:

Compensation is to be provided for consumption supplied via a **Dy1** transformer while line measurement voltage will be taken from its primary side (D stands for delta connection) and measurement current signal from a metering current transformer at the power supply transformer's secondary side (y stands for wye, or star, connection).

determining type of connection (parameter 15):

1. The transformer's primary side is delta-connected and line primary voltage will be connected to the controller (usually via a metering voltage transformer with nominal output AC) — this means the measurement voltage will be connected **in accordance** with the type of transformer.
2. Since the measurement voltage is connected **in accordance** with the type of transformer, the transformer phase angle (1) is **odd**, you set the type of measurement voltage configuration to **line**. (If the transformer phase angle was even or if the measurement voltage was not connected in accordance with the type of transformer, you would specify a different connection configuration).

Example 2:

Compensation is to be provided for consumption supplied via a **Yy6** transformer while the measurement voltage will be taken from its secondary side (y stands for wye, or star, connection) and the measurement current signal from a metering current transformer at the power supply transformer's primary side (Y stands for wye, or star, connection again).

determining type of connection configuration (parameter 15):

1. The transformer's secondary side is wye-connected, but the line secondary voltage is connected to the controller — this means the measurement voltage will be connected **in disaccordance** with the type of transformer.
2. The measurement voltage is connected **in disaccordance** with the type of transformer, the transformer phase angle (6) is **even**, so you set parameter 15 to **line**. (If the measurement voltage was connected in accordance with the type of transformer, you would specify a different phase connection).

If in doubt about correctness of determining the type of connection, experimental validation is convenient: after automatic connection configuration detection process you can usually compare the power factor value shown by the controller with information on the billing electricity meter (revolutions of active and reactive electricity meters). If in discrepancy, you have to set the connection configuration to the other value and repeat the validation test.

4.1.10 Parameter 17 – Metering Voltage Transformer (VT) Turns Ratio

This parameter allows specifying the voltage transformer turns ratio from 10 to 5000 or if unspecified.

Parameter is unspecified by default: “———” is displayed. In this event it is assumed that measurement voltage is connected directly. Measurement voltage values are then displayed directly.

If the measurement voltage is connected via a voltage transformer, its turns ratio can be specified by this parameter (example: if a voltage transformer with conversion 35kV/100V is used, 350 is specified). If no voltage transformer turns ratio is specified, all voltage and power measurement values are transformed to the voltage transformer's secondary side. If the voltage transformer turns ratio is specified correctly, the aforementioned values are displayed as values corresponding to the transformer's primary side and voltages are shown in kilovolts.

The value specified in parameter 17 does not affect the controller's control operation and only affects displayed values that are voltage or power. Therefore the value may be specified after the automatic section power recognition process, without having to start this process.

4.1.11 Parameter 18 – Compensation System Nominal Voltage (U_{NOM})

Parameter U_{NOM} determines the compensation system nominal voltage in volts or, if the voltage transformer turns ratio value is entered in parameter 17, in kilovolts. It is phase voltage or line voltage, depending on the type of measurement voltage (parameter 15).

If the type of connection is specified manually (parameter 15), parameter U_{NOM} is preset to its default value – for phase voltage ($\mathbf{Y}=\mathbf{\Delta N}$) U_{NOM} is preset to 230 V, for line voltage ($\mathbf{Y}=\mathbf{\Delta \Delta}$) to 400 V. The actual U_{NOM} value is further entered by the controller **within each automatic connection configuration detection process** to one of the values in Table 3.1 depending on the measurement voltage value.

Unless the compensation system nominal voltage value is untypical, it is usually not necessary to change the U_{NOM} value recognized. If otherwise, the parameter value can be edited from 50 to 750 V (if voltage transformer conversion is used, the value is displayed in kV after conversion).

Undervoltage and overvoltage alarm threshold values (parameter 31,32) are related to the U_{NOM} value.

The U_{NOM} parameter value can be at any time later edited without affecting each section's actual power value (parameter 25). Sections' actual power values (for example as they were detected in the latest automatic section power recognition process) are kept in the controller, only their displayed *nominal* values, which are related to the U_{NOM} value, are affected.

4.1.12 Parameter 20 – Automatic Section Power Recognition Process

The controllers are shipped with default setting of enabled automatic section recognition power process (parameter 20 set to \mathbf{A} , $\mathbf{AX}=\mathbf{A}$). With this setting, the controller carries out the automatic section power recognition process on controller powerup (introduction of power supply voltage) if none of the compensation sections is specified at a valid power value (see parameter 25). This condition always takes place with the first installation or *initialization* of the controller or after unsuccessful previous automatic section power recognition process. If at least one of the compensation sections is at valid power value, the automatic section power recognition process is not carried out.

If the parameter is set to $\mathbf{1}$, the controller carries out the automatic section recognition power process every time the controller is powered up, irrespective of the section values having been recognized before or not.

The process can also be started without interrupting power supply voltage, by editing parameter 20 to value $\mathbf{1}$ or by controller initialization (see further below).

If the automatic section power recognition process is enabled, it makes no sense to set parameters 21 through 24, therefore these parameters are not shown.

The automatic section power recognition process can be disabled by setting parameter 20 to $\mathbf{0}$. In such an event, sections' values must be entered using parameters 21 through 24.

Comment : If *linear switching mode* (see parameter 21) is set, the automatic section power recognition process cannot be enabled.

4.1.13 Parameter 21, 22 – Switching Program, Selection of Linear Switching Mode and Smallest Capacitor (C/ k_{MIN}) Nominal Power

If the Automatic Section Power Recognition Process is disabled, these parameters allow entering the value of each section or setting the "Linear Switching Mode".

If you select one of the preset combinations for parameter 21 as shown in Table 4.3, you select a "switching program" that specifies the ratios of all capacitor sections' values.

When selecting a switching program, the capacitors have to be connected to the controller's outputs in sequence where the lowest weight capacitor is connected to output 1. The number of capacitors

connected needs entering in parameter 23. If this number is more than 5, the controller a weights of sections 6 and higher are the same as the weight of section 5.

Table 4.3: Switching Program

| # | combination | displayed | # | combination | displayed |
|---|-------------|--------------|----|-------------|-------------|
| 1 | 1:1:1:1:1 | 1111 | 7 | 1:2:2:2:2 | 1222 |
| 2 | 1:1:2:2:2 | 1122 | 8 | 1:2:3:3:3 | 1233 |
| 3 | 1:1:2:2:4 | 11224 | 9 | 1:2:3:4:4 | 1234 |
| 4 | 1:1:2:3:3 | 1123 | 10 | 1:2:3:6:6 | 1236 |
| 5 | 1:1:2:4:4 | 1124 | 11 | 1:2:4:4:4 | 1244 |
| 6 | 1:1:2:4:8 | 11248 | 12 | 1:2:4:8:8 | 1248 |

If none of the preset combinations corresponds to the the combination required, you can section's value as you desire by editing parameter 25. In such an event, parameter 21 va automatically becomes undefined, ---, which means "individual switching program". Para loses its meaning and it is therefore not displayed.

Having selected the switching program as shown in Table 4.3, you still need to specify th power value of the smallest (corresponding to weight 1) capacitor C/k_{MIN} (parameter 22) i (although the controller measures in single phase, the value corresponds to the three-ph total value). CT ratio (parameters 12, 13) and U_{NOM} nominal voltage (parameter 18), poss ratio (parameter 17), values have to be already correctly specified in the instrument prior the aforementioned smallest capacitor power value – only then the smallest capacitor's r specified is actual.

The smallest capacitor nominal value is to be taken from its identification plate or checke measuring its phase current with a clamp-on ammeter. Table 4.4 shows phase current v most usual three-phase compensation capacitors.

Table 4.4: Capacitor's Phase Current Value (for $U_s=400V$)

| | | | | | | | | |
|----------|------|------|------|------|------|------|------|-------|
| Q [kvar] | 2 | 3.15 | 4 | 5 | 6.25 | 8 | 10 | 12.5 |
| I [A] | 2.9 | 4.6 | 5.8 | 7.2 | 9.0 | 11.6 | 14.5 | 18.1 |
| Q [kvar] | 15 | 20 | 25 | 30 | 40 | 50 | 60 | 100 |
| I [A] | 21.7 | 28.9 | 36.1 | 43.4 | 57.8 | 72.3 | 86.7 | 144.5 |

If parameter 21 is set to **A**, no switching program is selected (section values have to be parameter 25) and the *linear switching mode* is enabled to switch harmonic filters. In this controller connects or disconnects compensation sections in the linear fashion, which me

- always the lowest in order not yet connected compensation section(s) is/are cor
- always the highest in order connected compensation section(s) is/are disconnec

Each section that is not permanently connected or permanently disconnected is consider a compensation section involved in the control process.

On setting the Automatic Section Power Recognition Process (parameter 20) to either **A** linear switching mode is disabled.

Warning ! It is strongly recommended not to activate linear switching mode at standard compensation applications, otherwise quality of control process will be decreased.

4.1.14 Number of Capacitors

If entering capacitors' currents manually using the switching program and smallest capacitor power (parameters 21, 22), it is also necessary to enter the number of capacitors connected – parameter 23. The value can be set within the range from 1 to the controller's number of outputs.

If using a smaller number of capacitors than the type of controller allows, it is necessary to connect the capacitors to outputs starting with output 1 (that is the unconnected outputs will be those with the highest ordinal numbers).

If the controller outputs are not all used for capacitor connections, the unused outputs can be used to connect compensation chokes. The controller assumes that the chokes are connected from the lowest free output up (that is starting with the section following the last capacitor output connected).

These chokes' currents can be entered in parameter 25, for each choke separately (careful, a choke's current must be entered as a negative value – positive polarity currents are considered capacitive sections by the controller!)

4.1.15 Parameter 25 – Compensation Section Nominal Power

Nominal power of each compensation output can be edited in the side branch of this parameter if necessary.

The values are displayed in kilovolt-ampere reactive, kVAr, and they correspond to the **nominal three-phase power** of the relevant section under voltage corresponding to the compensation system nominal voltage U_{NOM} (parameter 18) value specified. To have the values correspond to the actual section (capacitor or inductance) compensation power, the current transformer turns ratio must be specified correctly as well (parameters 12, 13) or voltage transformer turns ratio (parameter 17) must. If these turns ratios are not specified, the section power values are displayed as if the turns ratio is 1.

Capacitive sections are shown as positive, inductive sections as negative values. If a section's current is not known (for example because of successful completion of the automatic section power recognition process), the ---- value is shown. In such an event, as well as in the event of section current zero value, the controller does not use the corresponding control output.

The controller is shipped with default setting of the automatic section power recognition process enabled (parameter 20 set to A). The automatic section power recognition process is started on introducing the power supply voltage, and after the process is complete, you can check or edit the recognized currents in the side branch of parameter 25.

Each section's nominal power can be changed even if it has been entered manually using the switching program and smallest capacitor current (parameters 21, 22).

If a section's value is shown with a flashing decimal point, it means:

- decimal point flashing **slowly** (about once a second), the section has not been accurized yet – see description of the mechanism to accurize sections in the relevant chapter further below
- decimal point flashing **fast** (about three times a second), the section has been disabled and the controller is not using it – see description of the mechanism to section disablement in the relevant chapter further below

If you change the U_{NOM} value (parameter 18), the controller will keep the actual section power value (for example from the latest automatic section power recognition process), only their displayed *nominal* value, reflecting the changes to U_{NOM} , will change.

4.1.16 Parameter 26 – Fixed Sections, Switching Cooling and Heating, Alarm

Any controller output can be set as fixed. In such a situation the output is permanently disconnected. The two highest outputs can further be used to switch cooling and heating of NOVAR 10xx models for alarm signalling too. The controller does not use sections set for power factor control.

4.1.16.1 Fixed Sections

A fixed output **maintains its preset condition** (that is connected or disconnected) with the following exceptions:

- the controller is switched to the **Manual** mode
- a selected nonstandard condition occurs while the alarm's corresponding alarm function has been set (for details see alarm description further below)

A fixed section (one set as permanently connected) is **only** disconnected if the alarm has been activated because of crossing over the threshold level of the quantity selected for a specific alarm (for details see description of alarm functions further below).

By default all controller's outputs are set as controlled, not fixed. In such an event they are set as follows:

01–X... output 1 is controlled and it is a capacitive section (capacitor)

12–Λ... output 12 is controlled and it is an inductive section (choke)

Each section's value can be set to **0** or **1**, that is **01–0** or **01–1**, respectively, in which case the corresponding output becomes a fixed one – it stays permanently disconnected or permanently connected.

4.1.16.2 Switching Cooling and Heating

The two highest outputs can be set to switch cooling (fan) and heating, for example as follows:

14–Φ...output 14 set to switch cooling (fan)

13–H...output 13 set to switch heating

With the above setting, these outputs are controlled in function of the measured instantaneous temperature. You can specify the threshold temperature to switch the cooling in parameter 60. If the temperature drops below the threshold value, the relevant output closes and vice versa. If the temperature exceeds the threshold value, the relevant output opens. Parameter 60 is for specifying the heating threshold temperature to make the relevant output is exceeded.

Switching thresholds' hysteresis is about 5°C.

4.1.16.3 Alarm Signalling (NOVAR 10xx only)

The two highest outputs can be used for Alarm state signalling at NOVAR 10xx controller. If the outputs to be used as Alarm relay, it is necessary to set the output to one of the following:

- **8–A** output 8 set to Alarm signalling; if Alarm state active, the output is **closed**
- **8–A.** (= „A“ with decimal point) output 8 set to Alarm signalling; if Alarm state active, the output is **closed**

When Alarm function set, Alarm state is indicated not only by **Alarm** LED, but by opening appropriate relay too.

4.1.17 Parameter 27 – Limit Power Factor for Compensation by Choke

This parameter specifies power factor value at which the controller starts using, besides capacitive sections, inductive compensation sections for compensation as well – chokes (if available).

If the power factor measured is more inductive (current more lagging) than the value specified in this parameter, the controller uses only capacitive sections (capacitors) to control compensation.

If the power factor in the power system changes so that it is more capacitive (current more leading) than the limit value for compensation by choke, the controller starts using combination of capacitive and inductive compensation sections for compensation.

By default this parameter's value is set as undefined (— displayed) in a shipped controller or after its initialization. With this setting the controller does not use chokes that are available (such sections are permanently disconnected) and it does not even detect available chokes in the automatic section power recognition process.

Compensation by chokes is described in more detail in an appropriate chapter further below.

4.1.18 Parameter 30 – Alarm Setting

NOVAR line controllers feature two alarm type functions that are independent of each other:

- alarm indication
- alarm actuation

4.1.18.1 Alarm Indication

In order to indicate nonstandard compensation conditions, the instruments feature an **Alarm** LED in the front panel and an Alarm relay potential-free contact accessible at a connector in the rear panel. At NOVAR 10xx models, that are not equipped with the dedicated Alarm relay, it is possible to use any of highest two outputs for Alarm signalling (see parameter 26).

Indication of a nonstandard condition occurrence shows as flashing **Alarm** LED and closed Alarm relay contact. In standard condition this LED is dark and the relay contact open. At NOVAR 10xx models, the relay state polarity is presettable, but it is always opened if voltage outage.

Nonstandard condition, at which alarm should be indicated, can be specified in the side branch of parameter 30. Any of the eight conditions shown in Table 4.5 can trigger the alarm indication.

Alarm indication from any nonstandard condition can be selected by editing such a condition in the side branch of parameter 30. The settings can take 4 different values:

1. **01–0**... condition 1 (undercurrent) is not indicated (neither does it trigger actuation – see description further below)
2. **01–Σ**... condition 1 (undercurrent) is indicated (but it does not trigger actuation)
3. **01–A**... condition 1 (undercurrent) is not indicated (but it triggers actuation)
4. **01–2**... condition 1 (undercurrent) is indicated (and it triggers actuation)

Alarm indication can be set for any other condition in the same manner as shown for condition 1 in the above example. For some conditions, alarm actuation can be specified besides indication (see description further below).

Alarm indication can be triggered by one or a combination of some conditions specified. Alarm indication will be triggered when the condition has been detected continuously for the time specified in Table 4.5 as the 1st value; the 2nd value (after „/“) defines elapse time to stop alarm indication after the condition disappears. The condition that has triggered alarm indication can then be checked in the alarm status (in the side branch of parameter 40).

Table 4.5: Alarm – Indication

| # | condition | description | minimum delay of activation / deactivation |
|----|---|--|---|
| 1 | undercurrent | current at metering current transformer's secondary side under minimum measurement current | 5 / 5 seconds |
| 2 | overcurrent | current at metering current transformer's secondary side over 120% of nominal value setting (6 A / 1.2 A) | immediately |
| 3 | voltage failure | measurement voltage not detected (< 30 Veff) | 5 / 5 seconds |
| 4 | undervoltage | voltage one-minute moving average value lower than the undervoltage threshold specified (parameter 31) | maximum 1 minute (depends on the extent of undervoltage) |
| 5 | overvoltage | voltage one-minute moving average value higher than the overvoltage threshold specified (parameter 32) | maximum 1 minute (depends on the extent of overvoltage) |
| 6 | THDI > | THDI one-minute moving average value higher than the THDI threshold specified (parameter 33); works on loads 5% and higher | maximum 1 minute (depends on the level of THDI) |
| 7 | THDU > | THDU one-minute moving average value higher than the THDU threshold specified (parameter 34) | maximum 1 minute (depends on the level of THDU) |
| 8 | CHL > | CHL one-minute moving average value higher than the CHL threshold specified (parameter 35) | maximum 1 minute (depends on the level of CHL) |
| 9 | compensation error | power factor fifteen-minute moving average value outside range 0.9L to 1.00; works on loads 5% and higher | maximum 15 minutes (depends on the level of power factor) |
| 10 | export | negative active power one-minute moving average value detected (flow of power from appliance to source) | maximum 1 minute (depends on the level of active power) |
| 11 | number of switching operations exceeded | number of connects and disconnects of a section has exceeded the limit setting | immediately |
| 12 | section error | permanently wrong section value detected in compensation (usually section failure) | 5 connections + 5 disconnections |
| 13 | overheated | temperature one-minute moving average value higher than the temperature threshold specified (parameter 37) | maximum 1 minute (depends on the level of temperature) |
| 14 | external alarm | second metering rate input switched on | 5 / 5 seconds |

Note: Conditions shown above in bold type are set by default.

Unlike alarm actuation described below, alarm indication setting has no effect on the inst control process.

Besides conditions mentioned above, alarm indication will also be triggered by a condition least one nonzero capacitive section has not been specified (when entering section value

or identified (in the automatic section power recognition process). Under this condition, flashing **X=0** is shown on the numeric display.

4.1.18.2 Alarm Actuation

Independently of the alarm indication function, you can set alarm actuation for some of the nonstandard conditions. Actuation means intervention in the control process, especially interruption of controller operation, usually with subsequent disconnection of compensation sections. See list of actuations in Table 4.6.

If you require that the controller respond to occurrence of an above nonstandard condition with its corresponding actuation as shown in the table, you have to set the condition of choice in the side branch of parameter 30 to **A** or **2** (see previous chapter).

Conditions not shown in this table do not trigger any actuations, hence they can not be set this way either.

Table 4.6: Alarm – actuation

| # | condition | minimum delay of activation / deactivation | actuation |
|----|------------------------|--|--|
| 1 | undercurrent | 10 / 5 seconds | disconnection of all sections except fixed ones |
| 3 | voltage failure | immediately / 5 seconds | disconnection of all sections |
| 4 | undervoltage | maximum 1 minute (depends on the extent of undervoltage) | disconnection of all sections |
| 5 | overvoltage | maximum 1 minute (depends on the extent of overvoltage) | disconnection of all sections |
| 6 | THDI > | maximum 1 minute (depends on the level of THDI) | disconnection of all sections |
| 7 | THDU > | maximum 1 minute (depends on the level of THDU) | disconnection of all sections |
| 8 | CHL > | maximum 1 minute (depends on the level of CHL) | disconnection of all sections |
| 10 | power export | maximum 1 minute (depends on the level of active power) | disconnection of all sections except fixed ones |
| 12 | section error | 5 connections + 5 disconnections | section disablement (see description in chapter below) |
| 13 | overheated | maximum 1 minute (depends on the level of temperature) | disconnection of all sections |
| 14 | external alarm | immediately / 5 seconds | disconnection of all sections |

Note: Conditions shown above in bold type are set by default.

4.1.19 Parameters 31 through 37 – Alarm Indication/Actuation Limits

If indication or actuation from a condition shown in Table 4.7 is set up, you also need to specify the relevant quantity's limit value exceeding which triggers the indication or actuation. The table shows parameter numbers where the limits are stored, limit setup ranges, and limit default values.

Number of switching operations limit (parameter 36) is shown in thousands.

If neither indication nor actuation from either of the two conditions has been set, the correct limit value is not shown.

Table 4.7: Alarm Limits

| # | condition | limit – parameter number | limit setup range | standard value |
|----|---|--------------------------|---|----------------|
| 4 | undervoltage | 31 | $50 \div 100 \% U_{\text{NOM}}$ (par. 18) | 80 % |
| 5 | overvoltage | 32 | $100 \div 200 \% U_{\text{NOM}}$ (par. 18) | 110 % |
| 6 | THDI > | 33 | $1 \div 300 \%$ | 20 % |
| 7 | THDU > | 34 | $1 \div 300 \%$ | 10 % |
| 8 | CHL > | 35 | $80 \div 300 \%$ | 130 % |
| 11 | number of switching operations exceeded | 36 | $10 \div 2000$ x thousand of switching operations | 1000 |
| 13 | overheated | 37 | $20 \div 60$ °C | 45 °C |

4.1.20 Parameter 40 – Alarm Status

If an indication function from a nonstandard condition is set (see description of parameter setting), you can view alarm's current status in the side branch of parameter 40.

Indication can be triggered by any of the nine conditions shown in Table 4.5. Parameter 40 provides detailed identification of condition that has triggered alarm indication. Alarm indication has been triggered by those conditions whose value is **1**.

4.1.21 Parameters 43, 44 – Total Section Connection Time and Number Switching Operations

In the side branch of these parameters you can check the time that each section has been connected for (parameter 43) and the number of switching operations for each section (parameter 44). Both values reset.

The total section connection time is shown in thousands of hours. If the number is low, you can view it at accuracy in the order of hours. Maximum value is 130 thousand hours.

The number of switching operations is shown in thousands. If the number is low, the value is shown with a decimal point so that you can view it at accuracy in the order of single events, tens of thousands of switching operations. Maximum value is 4 million switching operations.

The numbers are kept in the controller's non-backedup memory and stored in backed up memory about every eight hours where it is maintained even on power supply outage. The numbers in the last eight-hour interval are lost on voltage failure or controller initialization.

If a section's contactor is replaced, the relevant output's switching operation counter can be reset by editing it.

4.1.22 Parameter 45 – Type of Controller Error

The controller carries out self-diagnostic tests in regular intervals during the compensation process. You can check the diagnostics' results in this parameter.

It shows **E-00** if no errors have occurred. If the value is other than zero, the controller has identified an error. Such a condition does not necessarily mean the controller is out of operation — in such an event the controller supplier must be contacted and told about the identification value of the type of error shown. Using this value, a specialist will then decide about the method of solving the problem.

4.1.23 Parameter 46 – Control Time

When optimising controller parameter settings, it is sometimes required to monitor control time in detail. You can view the control time's current value in this parameter – it is shown in seconds as countdown to the next control intervention.

For monitoring the control time to make sense, the control operation must not be halted — therefore the control operation is enabled while viewing this particular parameter. Another difference while viewing this parameter is automatic jump back to display of values measured; this automatic jump takes only place after having viewed the control time for about 5 minutes from the last button press (it takes place as soon as in about 30 seconds while viewing any other parameters).

4.1.24 Parameters 50, 51, 52 – Instrument Address, Communication Rate and Communication Protocol

These parameters are only important in instruments featuring remote communication interface.

When setting up remote communication you have to specify the instrument's address (parameter 50) to one of the values from 1 to 253 (addresses 0, 254, and 255 are dedicated to special functions – do not use them). If a number of instruments are connected to the communication line, each instrument must have a different address.

The communication rate (parameter 51) can be set to one of the values: 4800, 9600, 19200 Bd.

The standard communication program uses a proprietary communication protocol, "KMB". The protocol is set as default in parameter 52, as **ΠO**. To facilitate implementation within user applications, the Modbus-RTU protocol can be used as well. The protocol can be set as **Π1N** / **Π1E** / **Π1O** (non parity / even parity / odd parity). Detailed description of both protocols can be downloaded at www.kmbsystems.eu or requested from the manufacturer.

The values specified will be kept even on controller's *initialization* (see description further below).

4.1.25 Parameter 55 – Power System Frequency

In order to obtain correct evaluation of measurement values, connected voltage and current sampling must be derived from the power system frequency. The controller measures the frequency on basis of voltage signal zero crossover rate. Voltage and current sampling then takes place in accordance with this parameter setting as follows:

Φ= A.... continuous sampling derived from frequency value measured (default setting)

Φ=50.... fixed sampling for power system frequency 50 Hz

Φ=60.... fixed sampling for power system frequency 60 Hz

Setting to **A** is optimum in most situations. Sampling of signals under measurement is continuously governed by measured frequency 10-second moving window average within the range from 43 to 67 Hz.

If the voltage signal is distorted to a degree when frequency can not be measured with sufficient accuracy, you can set up the parameter to 50 or 60. The measurement signals are then sampled at the fixed rate specified with no regard to the frequency measured.

4.1.26 Parameters 56, 57 – average, maximum, minimum value evaluation window

Besides displaying instantaneous measurement quantities, the controller also evaluates average and extreme (maximum/minimum) values. The evaluation window size for maximum, minimum, harmonic components, and temperatures is fixed (1 minute) while it can be specified in a range from 1 minute to 7 days for the other quantities, as shown in Table 4.8.

At the default setting shown above, the quantities Acos, APac, and APre contain the value of power factor, average active power, and average reactive power, respectively, for the last reset. Analogously the quantities mincos, maxPac, maxPre, and maxdPre contain the minimum value of power factor, maximum value of 1-minute moving averages of active power, maximum value of 1-minute moving averages of reactive power, and maximum value of 1-minute moving averages of difference between actual and required reactive power, respectively, for the last reset.

Table 4.8: average and extreme power and power factor value evaluation window

| param. | description | default value |
|--------|--|---------------|
| 56 | window size for evaluation of average power factor, Acos, and average power, APac, APre. | 7 days |
| 57 | window size for evaluation of minimum power factor, mincos, and maximum power, maxPac, maxPre, and maxdPre | 15 minutes |

Moving window size can be selected of **1-15-1H-8H-1D-7D**, that is 1 minute – 1 hour – 8 hours – 1 day – 7 days. On changing the evaluation moving window size, the average and extreme values are automatically cleared and the evaluation restarted.

4.1.27 Parameter 58 – Temperature Display °C / °F

This parameter specifies if the temperatures measured are displayed in degrees Celsius or Fahrenheit.

The measurement quantities of instantaneous temperature (Temp), maximum temperature (maxTemp) and parameters overheating alarm limit (parameter 37), heating switching threshold (parameter 59), and cooling switching threshold (parameter 60) are all displayed using the specified and indicated with symbols $^{\circ}\text{X}$ or $^{\circ}\Phi$.

4.1.28 Parameters 59, 60 – Cooling and Heating Switching Thresholds

If an output is set up to switching cooling or heating in parameter 26, you can specify the temperature threshold required in parameter 59 or 60. The switching temperature hysteresis is 5°C. The ranges and default thresholds are shown in Table 4.1.

If none of the output is set up to switching cooling or heating, the corresponding threshold is not displayed.

4.2 Section Value Accurization

If the controller is set up to automatic section power recognition process, that means parameter set to **AX=A**, or **AX=1**, it carries out the automatic section power recognition process first initialization or reinitialization or on resuming power after a power failure.

After successful completion of the automatic section power recognition process, it records power values measured and starts the control process. All power values measured are "not yet precise". A section, the value of which is not yet precise, can be identified by **slowly**

decimal point (as opposed to fast flashing decimal point to identify a disabled section – see description further below).

The controller measures the sections continually within the control process as they are connected and disconnected. It evaluates the average value measured for each not-yet-precise section and, when having received about 100 values, it rewrites the original section value, which was obtained in the automatic section power recognition process, with it. At the same time it tags the section as “precise” and stops further accurization of such a section.

This way, possible inaccuracies in the automatic section power recognition process are removed.

If the sections' values are specified manually (using the switching program and smallest capacitor power or by editing section value in parameter 25), no subsequent accurization takes place. Neither is accurization of choke sections, if present, carried out.

If the automatic section power recognition process is enabled, the accurization process can be automatically started anytime during the control process as well. If the controller detects that a compensation capacitor has repeatedly been showing a value different from that measured in the automatic section power recognition process and the difference is not in order of magnitude (that is in the interval from a half to double value) from the value recorded in the controller, the accurization process for such a section will start. Thus effects of changes in compensation capacitor values, for example as a consequence of the forming process after installation or due to aging etc., can be eliminated.

4.3 Faulty Section Indication and Disablement

In the alarm setting (parameter 30) you can choose alarm indication or actuation from detecting a faulty section (section error).

If at least one of these functions has been set, the controller continually checks reactive power changes in the power system during the control process as the sections are connected and disconnected and compares them with each section's power recorded. If connecting and disconnecting a section does not repeatedly result in adequate change to reactive power in the power system (or a change to reactive power measured is very different from the capacitor's value recorded), the controller tags such a section as faulty and, if relevant alarm actuation has been set, it will disable the section and stop using it in further compensation temporarily.

Alarm indication can be used for section disablement indication (see description of parameter 30). If alarm actuation is not set, the controller will only tag the faulty section, trigger alarm indication, but will keep using the section in compensation. A particular faulty section can be identified by **fast** flashing (about three times a second) decimal point in the section value display in the side branch of parameter 25 (as opposed to slowly flashing decimal point identifying not-yet-precise section – see description in chapter above).

A section that has been temporarily disabled is periodically, about every five days, checked by including it in compensation for one switching operation. If the controller detects a relevant response in the power system (within adequate allowance) to connecting the section, it will include the section in the control process again and, if the automatic section power recognition process is enabled, it will run accurization process for it too. This way, for example, a repaired section is automatically included in compensation (after replacing section fuse, for instance).

If the controller does not put a disabled section back to compensation automatically, such reinclusion in the control process will take place in the following situations:

- power supply interruption or controller initialization (see description further below)
- editing the section's value or one of parameters 21 through 23 (switching program, smallest capacitor value, number of capacitors).

- automatic section power recognition process

Faulty section indication and disablement can only be set for capacitive sections – choke present, are not checked.

4.4 Compensation by Choke

The instrument allows connecting chokes for power system decompensation. The decomp system can be built as combined, in which case both chokes and capacitors are connected to the controller, or only chokes are connected. If there are no capacitors used in the system, the power factor is derived from power of the smallest choke connected.

Compensation by choke is conditioned by compensation by choke power factor limit value (parameter 27) within a range from 0.8 lag to 0.8 lead. If this parameter is not defined (—) compensation by choke does not take place (if chokes are available at some of the outputs and outputs are permanently disconnected).

If the compensation by choke power factor limit value is specified as a valid setting, a choke is connected in the following situation:

- controller has disconnected all capacitive sections
- power factor is still more capacitive (leading) than that required and also more capacitive than the compensation by choke power factor limit value specified
- this condition has lasted for five times longer than the overcompensation control time (parameters 3, 9)
- a choke is available at least at one output and it has such a value that after its connection it will be possible to control the power factor to desired value using a combination of capacitive sections, that is large undercompensation will not occur after its connection

If a number of chokes are available to the controller, the most suitable one, depending on its power factor, is connected, and another one is connected if the above described situation has lasted for five times longer than overcompensation control time specified.

If a combination of chokes are connected and undercompensation occurs, such a number of chokes are disconnected after a normal undercompensation control time has elapsed (parameter 9) to prevent overcompensation.

It is recommended that decompensation chokes to be connected to outputs 5 and higher. Outputs 1 through 4 are reserved for capacitive sections, since the controller uses these outputs in the connection configuration detection process. Nevertheless, even the outputs 1 through 4 can be used for chokes – but the automatic detection process cannot be used and parameter 16 must be set manually in such case.

The automatic section power recognition process can also be used to determine values of chokes connected, but the compensation by choke limit power factor (parameter 27) must be specified as a valid value prior to this. If this parameter value has not been specified (—, — shown), chokes will not be detected.

After controller initialization, parameter 27 value is not specified, so compensation by choke is disabled by default.

4.5 Control Interruption

If the controller is in the automatic control mode (not in the **Manual** mode), one of the values measured is shown on the numeric display (**Measurement** display mode) and the controller carries out control process based on the values measured and parameter settings.

If you switch to parameter display, the control process will be interrupted. Output relays will stay in the state they were at the moment of switching over the display mode. The controller assumes the operator wants to check or change some of the parameters and it does not change the state of outputs until this has been finished (provided no nonstandard conditions, such as measurement voltage failure, have occurred, of course). At the moment of switching back to display mode, the instrument continues the control process.

If the operator did not switch back to the **Measurement** display mode, the controller would switch to the mode automatically in about thirty seconds from the last button press.

An exception is showing the control time (parameter 46) – in this event the control interrupted will resume for operator to be able to check control process operation. The display will switch to showing instantaneous values after about 5 minutes automatically.

Analogously to control interruption, the automatic connection configuration detection process or automatic section power recognition process will be interrupted by the above mentioned procedure if in progress. It, however, starts over from the beginning again once resumed.

4.6 Manual Mode

When installing or testing the controller it may sometimes be required to check the function of each compensation section or it is necessary to put the automatic control process out of operation for a rather long time.

In such situations, you can switch the controller to a mode in which it only carries out measurements and displays the values. You can switch to this mode by pressing buttons **M** and **P** (or buttons ▲ and ▼ for NOVAR 10xx models) and holding them down simultaneously for about 6 seconds (until the **Manual** LED starts flashing). You can switch back to the automatic control mode analogously.

You **can not** view or edit the controller's parameters in the **Manual** mode – you can only close or open each of the controller's outputs.

On switching the regulator to the **Manual** mode, the outputs stay in the state they were in during the control process before switching over the modes. You can then change the states of the outputs manually – after pressing button **P** (►) the state of a corresponding output is shown (for example **01–0**, which means output 1 is off – contacts open) and you can scroll through them all using buttons ▲ , ▼ and edit them very much like the instruments' parameters. The outputs' states change while being edited, respecting the reconnection delay time specified.

If the controller is in the **Manual** mode and there is a supply voltage failure, the **Manual** mode is resumed on power recovery. At this, all outputs that were on before the failure get switched on one by one again (the states of outputs are remembered).

Warning ! Alarm actuation (parameter 30) is disabled in **Manual** mode !

4.7 Manual Intervention in Control Process

In order to be able to check the controller's response to a control deviation change, it is possible to connect or disconnect a section by operator's manual intervention, not only in the **Manual** mode but also within the automatic control process.

While holding button **M** pressed down you can connect or disconnect a section using button **▼** and watch the controller's response to the change of condition. Each button press connects or disconnects one compensation section, always the one with the smallest value (except in linear switching mode the order of connecting/disconnecting is specified in description of 21). Reconnection delay time is respected when connecting.

If the controller is left in the automatic control mode, it will carry out evaluation and control after the control time has elapsed thus putting the unbalanced conditions in the power supply into a compensated state.

4.8 Controller Initialization

In some situations it may be necessary to put the controller back to its default settings as shipped. You can do this using controller *initialization*. After initialization has been run, the controller starts too, that means the controller carries out all the operations as if the power supply was introduced.

The controller's parameters are set to the values shown as default in Table 4.1 on initialization; the following parameters:

- metering current transformer nominal secondary value (13)
- type of measurement voltage (phase or line, 15)
- instrument address, communication rate and protocol in instruments with RS485 interface (50, 51, 52)

These parameters remain unchanged, at the values specified before initialization.

The counters of connection time and switching operations (parameters 43, 44) are not affected by initialization either.

You can start the controller initialization by pressing buttons **M**, **P**, and **▼** (or buttons **▲** at NOVAR 10xx models) simultaneously and holding them down for about 6 seconds. The controller will first disconnect all sections connected and run the initial test – this is when you can release the buttons. Then it will carry out the initialization routine properly and since parameter 16 is defined, it will start the automatic connection configuration detection process.

Warning! The *Manual* mode is terminated on initialization if active! The controller is always in automatic control mode after initialization!

4.9 Capacitor Harmonic Load factor (CHL)

One of the measurement quantities is Capacitor Harmonic Load, CHL, factor. This quantity measures the total load of capacitors by current and with alarm actuation enabled, it can be used to protect the capacitors against overload. This factor's definition follows.

Compensation capacitors' service life depends on not exceeding operation limits. One of the limits is the capacitors' maximum current. This may be exceeded with voltage harmonic distortion and a capacitor's inductance being a function of the frequency.

If voltage is not distorted (sinus), the capacitor current is

$$I_c = \frac{U}{Z_c} = \frac{U}{\frac{1}{2\pi f C}} = 2\pi f C U \quad [A] \quad [1]$$

where :

| | |
|---------------------------|--------|
| Ic... capacitor current | [A] |
| U... capacitor voltage | [V] |
| Zc... capacitor impedance | [Ω] |
| f... frequency | [Hz] |
| C... capacitor capacity | [F] |

If the voltage is distorted, the current flowing through a capacitor forms as the sum of current harmonic component vectors

$$\bar{I}_C = \sum_{i=1}^n \bar{I}_i \quad [A] \quad [2]$$

and magnitude of each harmonic component is pursuant to formula [1]

$$I_i = 2 \pi f_i C U_i = 2 \pi (f_i \times i) C U_i \quad [A] \quad [3]$$

where :

| | |
|--|--------|
| i... order of harmonic | [-] |
| I _i ... current of i th harmonic component | [A] |
| U _i ... voltage of i th harmonic component | [V] |
| f _i ... frequency of i th harmonic component | [Hz] |
| f ₁ ... fundamental harmonic frequency | [Hz] |

According to formula [3], the magnitude of current of each harmonic component is proportional to a multiple of voltage and its order (U_i x i) of harmonic. Consequently, the total harmonic distortion, which is defined as

$$THD_U = \sqrt{\sum_{i=2}^N \left(\frac{U_i}{U_1} \right)^2} \quad [\%] \quad [4]$$

where:

| | |
|--|-------|
| THD _U ... voltage total harmonic distortion | [%] |
| U _i voltage of i th harmonic component | [V] |
| U ₁ voltage of fundamental harmonic component | [V] |

is not suitable as a criterion of capacitor current overload due to harmonic distortion, because it does not respect distribution of harmonic components across their spectrum.

Therefore the capacitor harmonic load factor is defined as follows

$$CHL = \sqrt{\sum_{i=1}^N \left(\frac{iU_i}{U_{NOM}} \right)^2} * 100 \quad [\%] \quad [5]$$

where :

| | |
|--|-------|
| CHL... capacitor harmonic load factor | [%] |
| i..... order of harmonic | [-] |
| U _i voltage of i th harmonic component | [V] |
| U _{NOM} ... nominal voltage | [V] |

This factor value does respect, besides respecting each harmonic component's voltage value, distribution of harmonic components of different orders across their spectrum and it addresses the effect of voltage values. It is thus a more convenient value to determine total load of a capacitor by current. If the nominal value voltage is undistorted, this factor is at value of 100%. The following table

shows CHL factor values for a few selected scenarios of harmonic distribution at fundam harmonic component nominal value.

Table 4.9: Examples of CHL factor values for selected distributions of voltage harmonic ($U_i=U_{NOM}$)

| No. | voltage harmonic component levels [%] | | | | | | | | | CHL [%] |
|-----|---|-----------------|-----------------|-----------------|------------------|------------------|------------------|------------------|------------------|-----------|
| | 3 rd | 5 th | 7 th | 9 th | 11 th | 13 th | 15 th | 17 th | 19 th | |
| 1 | 2.5 | 3.5 | 2.5 | 1.0 | 2.0 | 1.5 | 0.8 | 1.0 | 0.5 | 110 |
| 2 | 3.5 | 4.5 | 3.5 | 1.2 | 2.5 | 2.0 | 1.0 | 1.5 | 1.0 | 118 |
| 3 | 5.0 | 6.0 | 5.0 | 1.5 | 3.5 | 3.0 | 0.5 | 2.0 | 1.5 | 133 |
| 4 | 5.5 | 6.5 | 5.5 | 2.0 | 4.0 | 4.0 | 1.8 | 2.3 | 1.8 | 146 |
| 5 | 8.0 | 9.0 | 8.0 | 6.0 | 7.0 | 7.0 | 2.3 | 4.0 | 3.5 | 208 |

Example 3 (CHL = 133%) corresponds to voltage harmonic distortion limits as specified i

4.10 Text Messages

In the measurement value display mode, a text message may appear in some situations instead of the instantaneous power factor value. Table 4.10 shows a list of these messages.

Table 4.10: List of text messages

| message | meaning | comment |
|---|---|---|
| AHOψ TEST N206 1.2 Y=Δv I=5A | initial sequence after power up or initialization - type of controller - firmware version - type of measurement voltage specified (phase, phase-neutral) - metering current transformer nominal secondary value specified | controller carries out self-diagnostics parameter 15 parameter 13 |
| Y=0 | measurement voltage not present or its fundamental harmonic component lower than minimum value | controller in waiting mode |
| I=0 | measurement current absent or lower than minimum value | controller in waiting mode |
| AIIvv | automatic connection configuration detection process in progress | process can have 1 to 7 steps |
| II=0 | automatic connection configuration detection process has failed and method of connection of measurement voltage and current (parameter 16) has not been defined | automatic connection configuration detection process will run again in about 15 minutes automatically or parameter 16 value can be entered manually |
| AX-v | automatic section power recognition process in progress | process can have 3 or 6 steps |
| X=0 | no capacitors have been successfully detected in automatic section power recognition process or in manual section value specification mode (parameter 20), parameters 21 through 26 have not been set properly or all capacitive sections have been automatically disabled because of error (parameter 25) or they are set as fixed (parameter 26) | if automatic section power recognition process is set, it will be automatically repeated in about 15 minutes or you can specify values of parameters 21 through 26 manually |

5. NOVAR1312 Description

5.1 Basic Operation

NOVAR1312 Power Factor Controller is a fully automatic instrument to allow optimized c reactive power compensation at up to 25 control interventions per second. It features tra outputs to drive thyristor switches and relay outputs to connect conventional contactors t cooling and heating, respectively.

NOVAR1312 design concepts are shared with those of NOVAR1214 and most of the fea operations are identical. NOVAR1312 differs from NOVAR1214 mainly in the following:

- outputs 1 through 12 are fitted with transistor
- control rate of the above mentioned outputs can be set to up to 10 intervention :

The following section of the manual therefore only deals with features and operations diff NOVAR1214. The other features are the same as those of NOVAR1214.

5.2 History of Firmware Versions

| version | date of release | note |
|---------|-----------------|----------------------------------|
| 0.1 | 3/2007 | - basic version |
| 1.2 | 10/2008 | - maximum control rate increased |

5.3 Installation

5.3.1 Transistor Outputs

The controller is equipped with 12 MOSFET-type transistors T1 through T12. Their open connected to terminals 18 through 29. Emitters are connected together to terminal 17.

These outputs are designed to connect to thyristor switches' input otpcouplers via limitir This is reflected in limit parameters of the transistor outputs as well: maximum voltage 10 maximum current 100 mA.

Figure 5.1: NOVAR 1312 – connectors

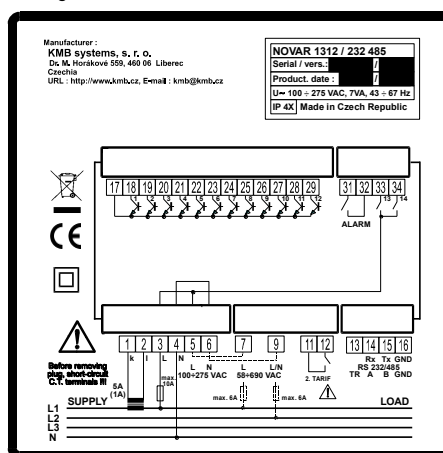

All of the transistor outputs in the group are galvanically insulated from the other controller circuits. The transistor outputs must be powered from the switching module's power supply or from an external power supply giving 10 to 30 V DC and protected with a fuse 0.3 to 0.5 A (for example ZP-24 that can be ordered from the controller supplier). The power supply's negative terminal post must be connected to the common terminal, number 17.

5.3.2 Relay Outputs

The instrument has 2 output relays, 13, 14. The relays' contacts go to terminals 33, 34. Relays' common contacts are internally connected to power supply terminal 3 (L) — when an output relay contact closes, power supply voltage appears at the corresponding output terminal.

The relays' output contacts are bridged with varistors.

5.4 Operation

5.4.1 Thyristor and Contactor Group

The controller features twelve transistor outputs, T1 through T12, and two relay outputs, R13 and R14. Thyristor switches can be connected directly to the transistor outputs. Contactors can be connected directly to the relay outputs. Thyristor switches must be connected successively starting with output T1 while the number of outputs used must be specified in parameter 28 on controller powerup (the parameter's default value is 0).

Display test will take place first on powerup. Information as described in Chapter 3.1 will then be displayed momentarily while the last parameter displayed is the number of transistor outputs used (such as $\tau=0$).

After that you have to set the parameter to the actual number of thyristor switches connected to the transistor outputs. The automatic connection configuration detection process and automatic section power recognition process follow in a standard way as described in Chapters 3.2 and 3.3.

Parameter 28 value defines the **thyristor group**, which is a group of outputs to which thyristor switches are connected. All the other outputs are the **contactor group**. Example: parameter 28 is set to 3 – outputs 1 through 3 are the thyristor group and outputs 4 and 14 are the contactor group.

The thyristor groups outputs are used by the controller for fast control process. The contactor group outputs are used for slow control process (see further below).

If not all the transistor outputs are used for connection of thyristor switches, the unused ones can be used for connection of contactors; contactors, however, must be connected to the transistor outputs via auxiliary relays (such as Schrack RT with 24 V DC coil). A wiring example is shown in an appendix.

5.4.2 Control Principles

Two simultaneous, into a degree independent, control processes take place in NOVAR1312 controller:

- fast control process with thyristor group outputs driving semiconductor switches
- slow control process with contactor group outputs switching contactors

Fast control process has a measurement stage, calculation stage and execution of control intervention. The control intervention rate, as well as the transistor outputs' reconnection delay time, can be specified to allow control process adaptation to power of the quick-discharge resistor used. The sections that only differ by less than a quarter from the transistor group's smallest section are considered equal by the controller and they are switched cyclically. When calculating the optimum

control intervention, only each control section's value is important (number of connections evaluated).

Slow control process has to respect limitations from the compensation section: parameters and service life. Phase measurement takes place once a second and timing, which can only repeat every five seconds, is determined by the control deviation control period specified. When calculating control intervention, the reconnection delay t is respected too. The optimum control intervention is chosen not only on basis of the speed but also from the point of view of the number of switching operations on each section, the last disconnection and the total number of switching operations within a control interval.

In an optimum case, the typical control process thus goes on like this: the fast process corrects small power factor deviations within fractions of seconds, and that appears as a condition to the slow process, so the contactor group outputs' states do not change. If the deviation in power factor then corresponds to the thyristor group's control capacity, the thyristor group outputs' states reach their limit (all connected or all disconnected). The slow process corrects the control deviation and the control time of this slow control process starts counting down. When the countdown elapses, control intervention using output relays is carried out.

A control intervention from the slow control process is carried out in such a way that the optimum condition is achieved while about one half of the thyristor group's compensation capacity is used. Under such optimum condition, the fast process is then able to respond to a change in power factor of either polarity in the power system.

An exception is a state, when only low compensation power is necessary. When the power necessary is lower than total capacity of thyristor group sections, a control intervention is carried out in the way to simply reach compensated state (not necessarily half of the thyristor group sections' compensation capacity should be connected).

5.5 Setup

NOVAR1312 has two more parameters in comparison with NOVAR1214:

- number of capacitors in thyristor group (parameter 28)
- thyristor group control rate and reconnection delay time (parameter 29)

Parameters 2 through 4, 14, 21 through 23, 43, 44, and 46 only relate to the contactor group NOVAR1312. The other parameters are the same as in NOVAR1214.

A complete list of parameters is shown in Table 5.1.

5.5.1 Parameter 28 – Number of Capacitors in Thyristor Group

It is necessary to enter the number of capacitors for fast compensation connected by thyristor switches when installing the controller.

Up to twelve capacitors for fast compensation can be connected. If using fewer capacitors than necessary to connect the capacitors to outputs starting with T1 in the group (that is, the thyristor outputs will be those with the highest ordinal numbers).

The value specified will be maintained even on controller *initialization* (see description further).

5.5.2 Parameter 29 – Thyristor Group Control Rate and Reconnection Delay

Although lifetime of thyristor switches is not limited by number of switching operations and switching at zero voltage no current spikes occur, the thyristor group control rate and reconnection time can be specified in this parameter.

It is because in some situations, the switching rate and reconnection delay time must be adopted to the fast-discharge resistors' power rating (these resistors are required for proper power thyristor switch operation if compensation capacitor overcharging takes place).

The value of the parameter is displayed as **P–N.N**, where

P..... number of control interventions per second

N.N... reconnection delay time in seconds

The control rate (= number of interventions per second) can be set in range 1 through 20 interventions per second. The reconnection delay time can be specified as shown in Table 5.2.

Note: If 10 control interventions per second are specified, "r" is displayed as 9 (for example **9–0.1**).

Table 5.2: Thyristor group control rate and reconnection delay time setting

| Control Rate [control interventions per second] | Reconnection Delay Time [seconds] |
|--|--|
| 1 | 1 - 2 - 5 - 10 |
| 2 | 0.5 - 1 - 2.5 - 5 |
| 3 | 0.3 - 0.7 - 1.7 - 3.3 |
| 5 | 0.2 - 0.4 - 1 - 2 |
| 10 | 0.1 - 0.2 - 0.5 - 1 |
| 20 *) | 0.0 |

*) real control rate depends on number of capacitors in thyristor group, see below.

Table 5.3: Real control rate at setting of 20 control interventions per second

| Thyristor Group Capacitors Number (parameter 28) | Real Control Rate [control interventions per second] |
|---|---|
| 1 ÷ 5 | >= 25 |
| 6 ÷ 7 | >= 20 |
| 8 ÷ 12 | >= 15 |

When shipped and after controller *initialization*, the values 1-10 are set, that means one control intervention per second and ten seconds of reconnection delay time.

5.5.2.1 Control Operation at the Highest Control Rate

At setting of the highest control rate, i.e. 20 control interventions per second, real control rate is not fixed, but it depends on preset number of the thyristor group capacitors number (parameter 28). General rule is the fewer capacitors the higher rate – see Table 5.3.

Furthermore, during frequency measurement that is performed each second, control cycle delay of approx. 30 milliseconds occurs. This delay can be eliminated by network frequency setting (parameter 55) to fixed value of 50 or 60 Hz, if it is possible. At such setting the controller doesn't measure the frequency and therefore no delay occurs. Measured frequency value is undefined.

Table 5.1: NOVAR1312 Parameters

| # | name | range | step | default | comment |
|--------|--|--|-------|--|---|
| 0 | parameter edit enable/disable | 0 / 1 | — | 1 | see Enable / Disable Parameter Editing |
| 1 | target power factor (metering rate 1) | 0.80 L ÷ 0.80 C | 0.01 | 0.98 L | |
| 2 | contactor group control time on undercompensation (met. rate 1) | 5 sec ÷ 20 min | — | 3 min | No "L": control time reduction by squared proportion "L": linear control time reduction. |
| 3 | contactor group control time on overcompensation (met. rate 1) | 5 sec ÷ 20 min | — | 30 sec | No "L": control time reduction by squared proportion "L": linear control time reduction |
| 4 | contactor group control bandwidth | 0.000 ÷ 0.040 | 0.005 | 0.010 | |
| 6 | metering rate 2 enable/disable | 0 – 1 – E | — | 0 | |
| 7 ÷ 10 | like parameters 1 ÷ 4, but for metering rate 2 | the same as parameters 1 ÷ 4 | — | — | Not displayed if metering rate 2 is disabled (parameter 6 = 0) |
| 12 | metering current transformer primary side nominal value | 5 ÷ 9950 A | 5 | none | |
| 13 | metering current transformer secondary side nominal value | 1 A ÷ 5 A | — | 5 | |
| 14 | contactor group reconnection delay time | 5 sec ÷ 20 min | — | 20 sec | |
| 15 | type of measurement voltage – phase or line | LN (phase) – LL (line) | — | LN | This parameter's correct setting is essential for automatic connection configuration detection process |
| 16 | method of connection of U and I | 6 combinations | — | none | see parameter description |
| 17 | voltage transformer turns ratio | direct or 10 ÷ 5000 | — | --- (direct) | ratio of metering voltage transformer nominal primary voltage to nominal secondary voltage |
| 18 | compensation system nominal voltage U_{NOM} | 50 ÷ 750 V x VT turns ratio | — | 230 / 400 V | controller establishes this value within the automatic connection configuration detection process |
| 20 | automatic section power recognition process | A (auto) – 0 (no) – 1 (yes) | — | A | |
| 21 | contactor group switching program | 12 typical combinations | — | none | 0 means individual section setting. Not shown if automatic section power recognition process is enabled. |
| 22 | contactor group smallest capacitor nominal power (C/ k_{MIN}) | (0.007 ÷ 1.3 kvar) x CT turns ratio x VT turns ratio | 0.001 | none | Value corresponds to U_{NOM} specified (parameter 18). Not shown if automatic section power recognition process is enabled. |
| 23 | number of capacitors in contactor group | 1 ÷ 14 | — | 14 | Not shown if automatic section power recognition process is enabled. |
| 25 | each section nominal power | (0.001 ÷ 5.5 kvar) x CT turns ratio x VT turns ratio | 0.001 | none | Value corresponds to U_{NOM} specified (parameter 18). Positive for capacitor sections, negative for choke sections. |
| 26 | fixed sections | regulated or 0 / 1 / F / H | — | all regulated | „F“ / „H“ for 2 highest sections only |
| 27 | choke compensation power factor limit | 0.80 L ÷ 0.80 C | 0.01 | none | if not specified, compensation by choke does not take place. |
| 28 | number of capacitors in thyristor group | 1 ÷ 12 | — | 0 | It must always be specified manually. The controller keeps the value specified on initialization. |
| 29 | thyristor group control rate and reconnection delay time | 1 ÷ 20 control interventions per second / 0.1 ÷ 10 seconds | — | 1 per second / 10 seconds | In effect for thyristor group only. |
| 30 | alarm setting | 0 / indication only / indication only / indication and actuation | — | ind. & act. from undercurrent, voltage loss or section error | 1... undercurrent 2... overcurrent 3... voltage loss 4... undervoltage 5... overvoltage 6... THDI > 7... THDU > 8... CHL > 9... compensation error 10... export 11... no. of conn.'s > 12... section error 13... overheated 14... external alarm |

| | | | | | |
|---------------|---|--------------------------|------|------------|--|
| 31 ÷ 37 | alarm thresholds: undervoltage, overvoltage, THDI, THDU, CHL, number of connections and temperature | — | — | — | Ranges and units as in Table 4.7 not displayed if the alarm not set up |
| 40 | alarm instantaneous condition | | | | Indicates current state of alarm. |
| 43 | section connection time (in thousands of hours) | | | | Display range 0.001 to 130 In effect for contactor group outputs only. |
| 44 | number of section connections (in thousands) | | | | Display range 0.001 to 4000. In effect for contactor group outputs only.. |
| 45 | instrument failure condition | | | | |
| 46 | instantaneous condition of control time | | | | time until next contactor group control intervention in seconds |
| 50 | instrument address (communication interface) | 1 ÷ 254 | 1 | 1 | not shown in instruments with no communication interface |
| 51 | communication rate (communication interface) | 4800 – 9600 – 19200 Bd | — | 9600 Bd | not shown in instruments with no communication interface |
| 52 | communication protocol (communication interface) | KMB(P0) / Modbus-RTU(P1) | — | KMB(P0) | not shown in instruments with no communication interface |
| 55 | power system frequency | A (auto) – 50 Hz – 60 Hz | — | A (auto) | |
| 56 | average value evaluation moving window size | 1 minute ÷ 7 days | - | 7 days | applies to average values of AcoS, APac, APre |
| 57 | minimum and maximum value evaluation moving window size | 1 minutes ÷ 7 days | - | 15 minutes | applies to these minimum and maximum values: mincos, maxPac, maxPre, maxdPre |
| 58 | Celsius/Fahrenheit temperature display mode | °C – °F | - | °C | |
| 59 | cooling enable threshold | +10 ÷ +60 °C | 1 °C | +40 °C | not displayed if cooling output not specified |
| 60 | heating enable threshold | -30 ÷ +10 °C | 1 °C | -5 °C | not displayed if heating output not specified |

6. Wiring Examples

NOVAR1007 – installation

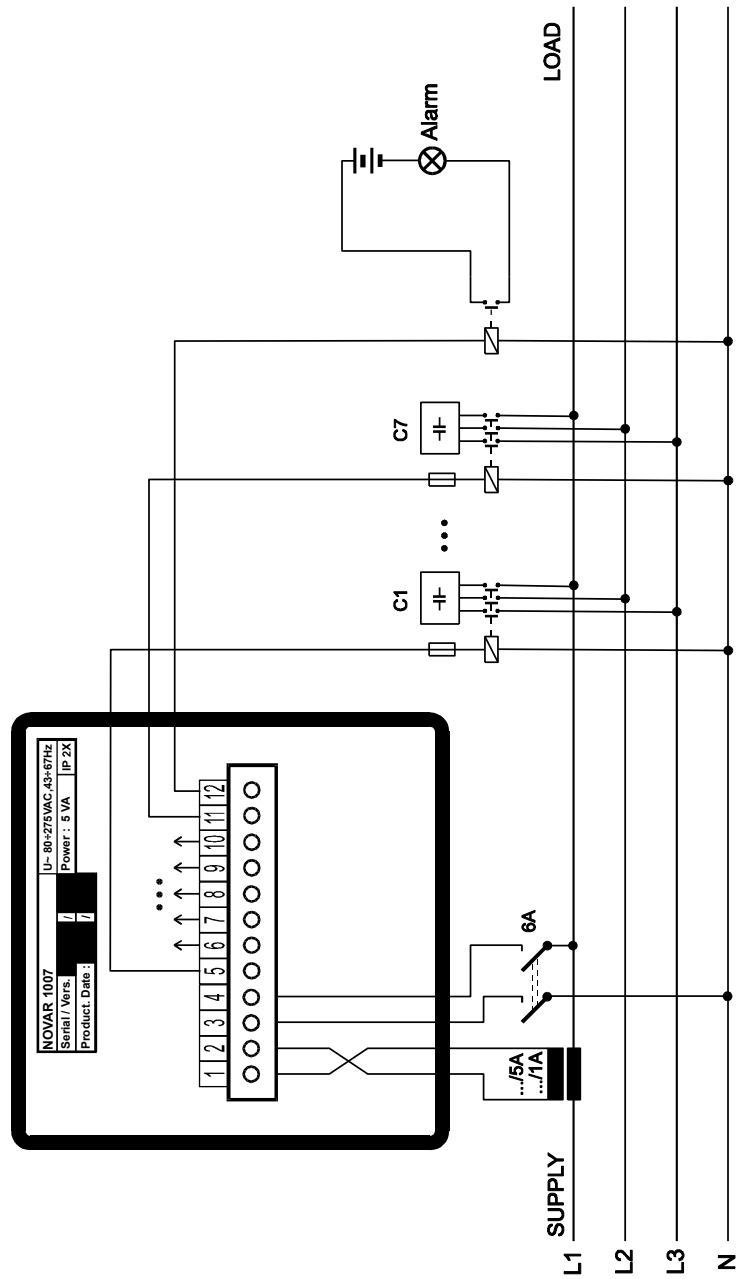

NOVAR1106 – installation

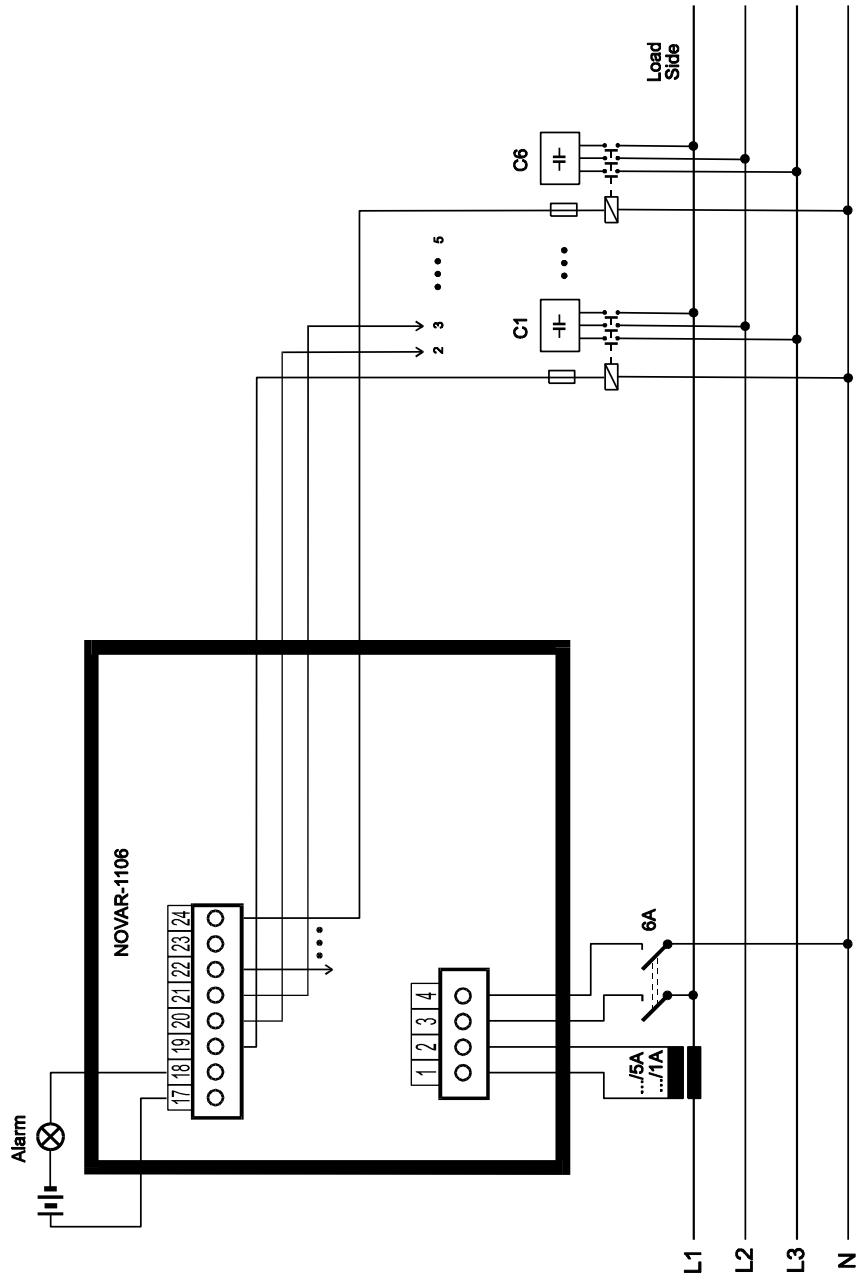

NOVAR1114 – installation

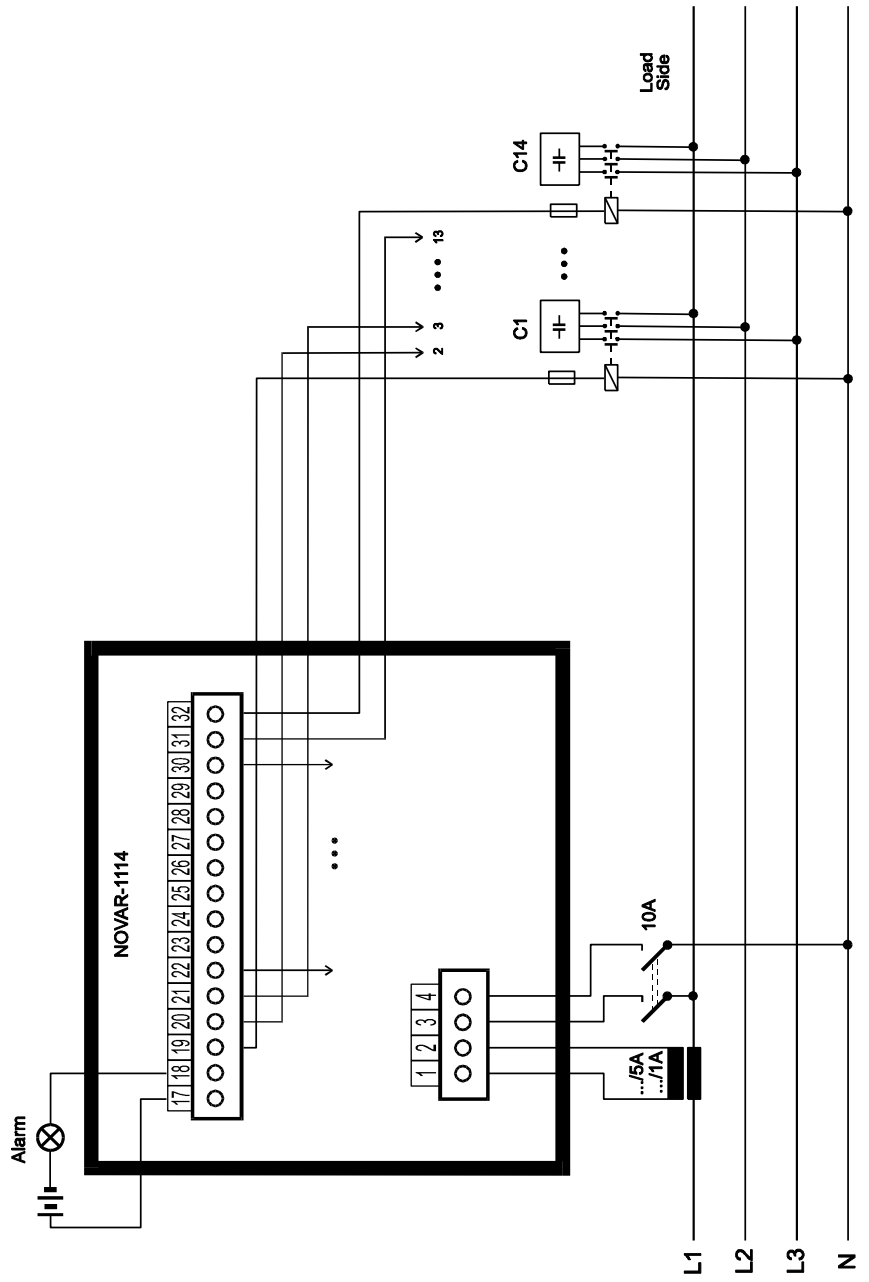

NOVAR1206 – installation, low voltage measureme

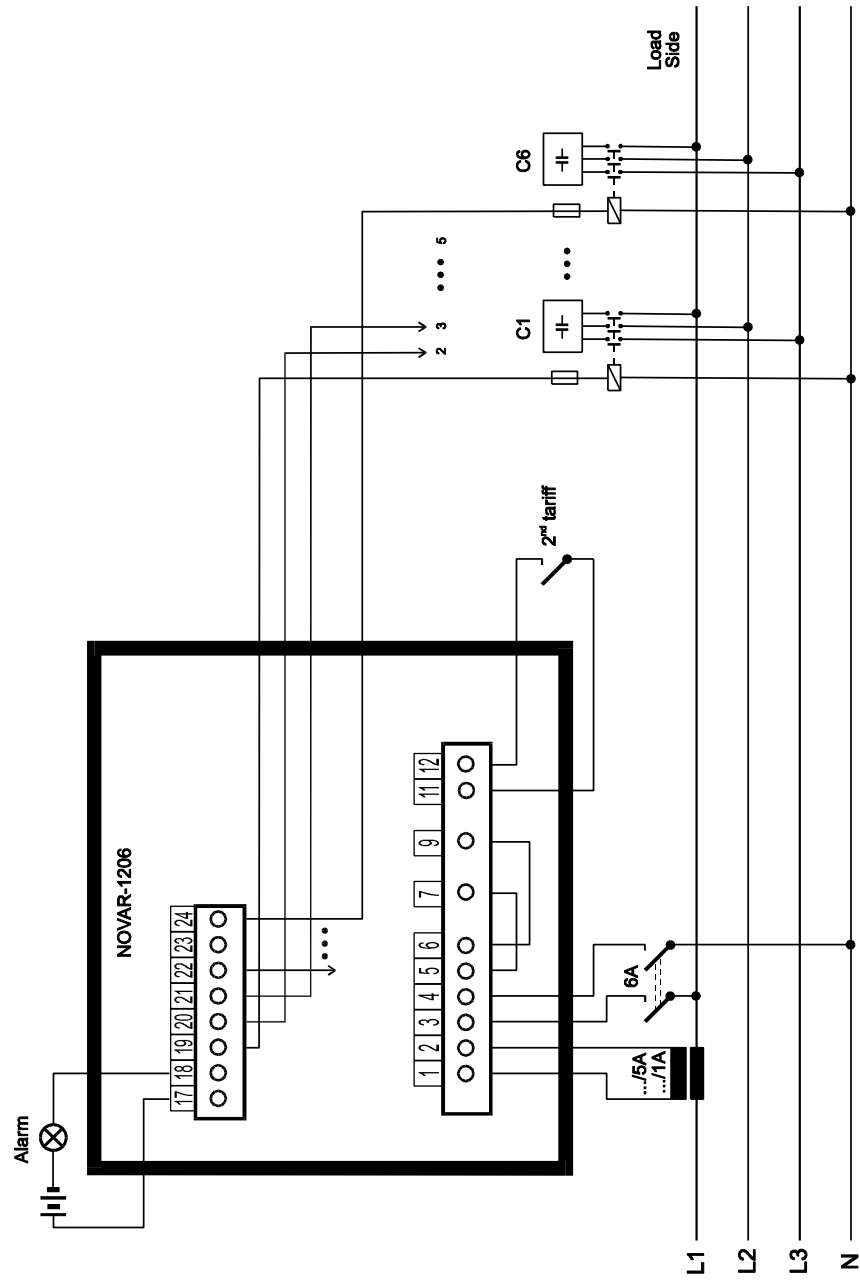

NOVAR1214 – installation, high voltage measurement

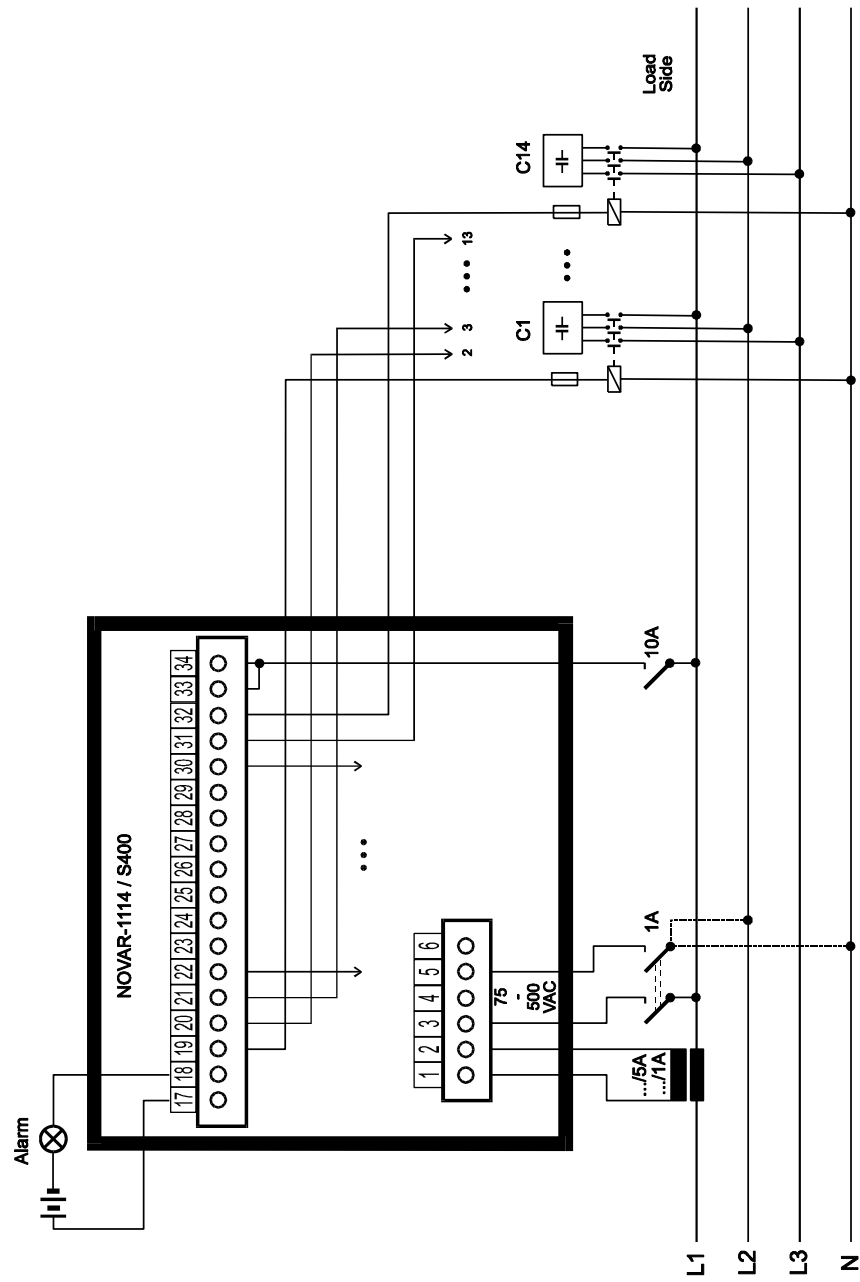

**NOVAR-1214/S400 – installation,
controller and contactors supplied from DC**

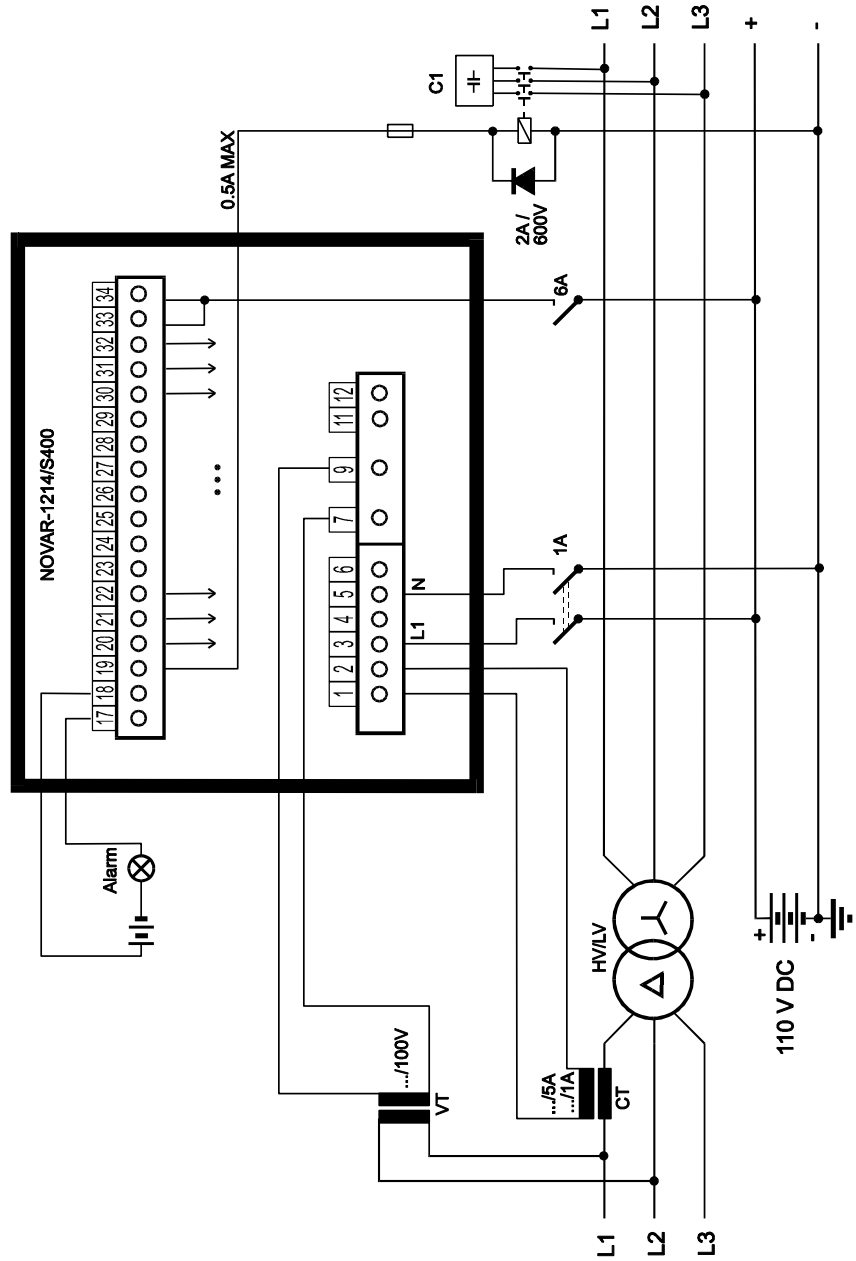

NOVAR1312 – installation, hybrid system with both the switches and contactors

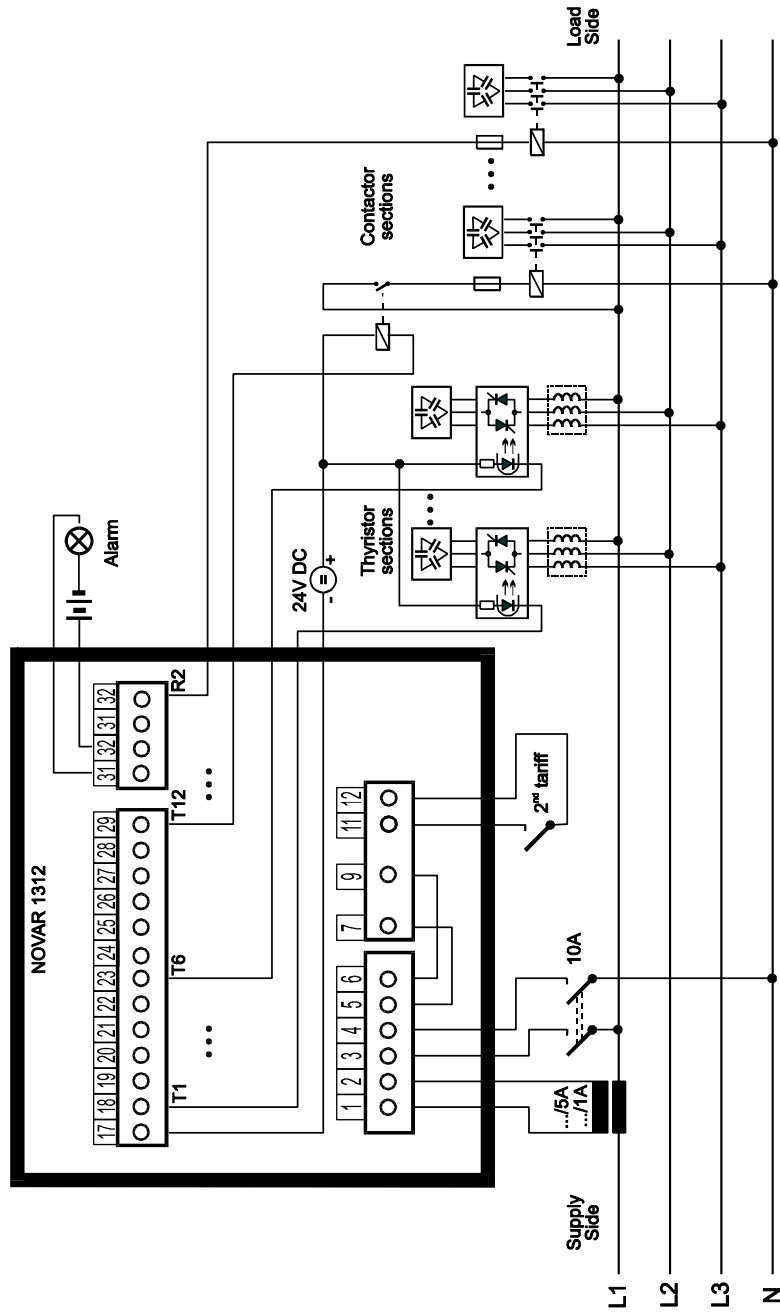

Novar - RS-485 communication link connection

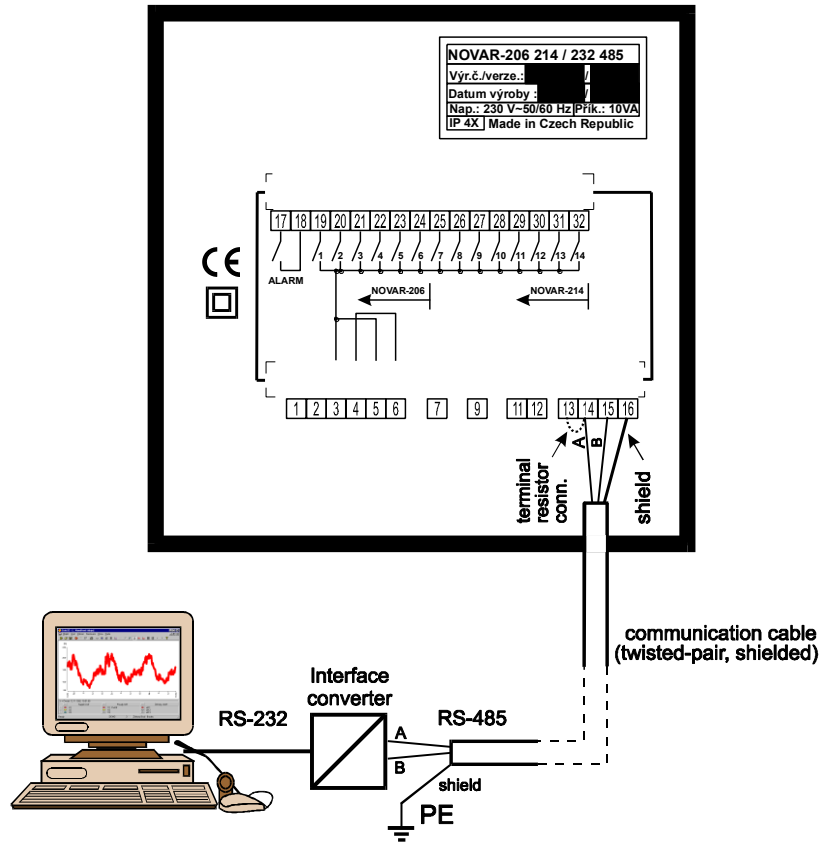

7. Technical Specifications

Adjustable Parameters

| parameter | NOVAR Model | | | |
|---|-----------------------------|--------------------------|-------------|--------------|
| | 1005 / 1007 | 1106 / 1114 | 1206 / 1214 | 1314 |
| power factor desired | 0.80 ind. through 0.80 cap. | | | |
| connection time (maximum value, depends on control deviation) | 5 to 1 200 seconds | | | 1 ÷ 25 / sec |
| reconnection delay time / control rate | 5 to 1 200 seconds | | | 0.1 ÷ 10 sec |
| smallest capacitor current | (0.02 ÷ 2 A) x CT | (0.002 ÷ 2 A) x CT ratio | | |
| compensation section values setting | automatic or manual | | | |
| connection configuration setting | automatic or manual | | | |

Inputs and Outputs

| | | | |
|---|---|--|--|
| power supply : standard version | 80 ÷ 275 V AC 43 ÷ 67 Hz, 5VA | 90÷275 V AC 43÷67Hz,7VA | 90 ÷ 275 V AC (43÷67 Hz) or 100÷300 V DC, 7VA |
| “/S400” version | — | 75÷500 V AC 43 ÷ 67 Hz | 75÷500 V AC 43 ÷ 67 Hz or 90÷600 V DC, 7VA |
| measurement voltage | the same as power supply voltage | | 57.7 ÷ 690 V AC, +10/-20%, 43 ÷ 67 Hz |
| voltage measurement accuracy | ±1% of range ±1 digit | | |
| voltage meas. input impedance | — | | > 800 kOhm |
| meas. voltage loss / external alarm response time (output disconnection) | <= 20 ms | | |
| measurement current (galv. insulated) | 0.02 ÷ 7 A | 0.002 ÷ 7 A | |
| current input serial impedance | < 10 mOhm | | |
| current measurement accuracy | +/- 0.02A +/- 1 dig. +/- 0.002A +/- 1 dig — | +/- 0.02A +/- 1 digit +/- 0.002A +/- 1 digit +/- 0.0005A +/- 1 digit | |
| max. phase angle error (PF & powers measurement) | +/-1° at I > 3 % of range, otherw. +/-5° | +/-1° at I > 3 % of range, otherwise +/-3° | |
| current harm. & THDI meas. accuracy | ±5 % ± 1 digit (for U, I > 10 % of range) | | |
| temperature meas. range / accuracy | -30 ÷ 60 °C, ± 5 °C | | |
| number of output relays | 6 / 8 | 6 / 14 | 12T + 2R |
| output relay load rating : | 250 V AC / 4 A 110 Vss / 0,3 A | | |
| • standard version | — | 250 V AC / 4 A ; 110 V DC / 0.5 A ; 220 V DC / 0.2 A (400 V AC for overvoltage cathegory II) | — |
| • “/S400” version | — | — | — |
| output transistor load capacity | — | — | max. 100 VDC / 100 mA |
| met. rate 2 input (galv. connected, for insulated contact / optocoupler) | — | — | 30 Vss / 5 mA |
| installation overvoltage class / level of pollution | III-2 in compliance with EN 61010-1 | | |
| • for voltage up to 300 V AC | — | | |
| • for voltage over 300 V AC | — | II-2 in compliance with EN 61010-1 | |

Communication

| | |
|---|---|
| Interface | RS 232 / RS 485, galvanically insulated |
| transmission rate | 4800 ÷ 19200 Baud |
| maximum number of instruments on one communication line | 1/32 |
| maximum node-to-node distance | 30 metres / 1200 metres |
| data transfer protocol | KMB / Modbus RTU |

Operating Conditions

| | |
|-----------------------|---------------------------------------|
| working environment | class C1 in compliance with IEC 654-1 |
| operating temperature | -40° ÷ +60°C |
| relative humidity | 5 to 100 % |

EMC

| | |
|-------------------------|---|
| noise suppression level | in compliance with EN 50081-2, EN 55011 , class A, EN 55022 , class A |
| Immunity | in compliance with EN 61000-6-2 |

Physical

| parameter | NOVAR Model | | | |
|---|---|---|-------------|------|
| | 1005 / 1007 | 1105 / 1114 | 1205 / 1214 | 1314 |
| enclosure <ul style="list-style-type: none"> • front panel • back panel | IP40 (IP54 option) | | | |
| dimensions <ul style="list-style-type: none"> • front panel • built-in depth • installation cutout | 96 x 96 mm 80 mm 92 ⁺¹ x 92 ⁺¹ mm | 144 x 144 mm 80 mm 138 ⁺¹ x 138 ⁺¹ mm | | |
| mass | max. 0.92*.3 kg | | max. 0.7 kg | |

8. MAINTENANCE, TROUBLESHOOTING

NOVAR line power factor controllers do not require any maintenance. For reliable operation you only have to comply with the operating conditions specified and prevent mechanical damage to the instrument.

The controller's power supply is one-pole protected with a mains fuse rated as T0.5A . The fuse is only accessible after back disassembly and only the controller supplier's qualified personnel may thus replace it.

In the event of the product's breakdown, you have to return it to the supplier at their address.

supplier:

Elias Ghali & Sons
Homs - Syria
P.O.Box : 64
Tel: +963 31 48 07 80
Fax: +963 31 22 76 38
E-mail : s.ghali@scs-net.org
Url: www.ghali-sy.com

manufacturer:

EPM Elektropřístroj s.r.o.
Mezi Vodami 1955
143 00 Praha 4 – Modřany
Czech Republic
Tel: +420 261 106 111
Fax: +420 261 106 106
E-mail : epm@epm.cz
Url: www.kmbssysteme.eu , www.epm.cz

The product must be packed properly to prevent damage in transit. Description of the problem or its symptoms must be sent along with the product. If warranty repair is claimed, the warranty certificate must be sent in too. If after-warranty repair is requested, a written order must be included.

Warranty Certificate

Warranty period of 24 months from the date of purchase, however no later than within 30 months from the dispatch date from manufacturer's warehouse, is provided for the instrument. Problems in the warranty period, evidently caused by poor workmanship, design or inconvenient material, will be repaired free of charge by the manufacturer or an authorized servicing organization.

The warranty becomes void even within the warranty period if the user makes unauthorized modifications or changes to the instrument, connects it to out-of-range quantities if the instrument is damaged in out-of-specs impacts or from improper handling or if it has been operated in conflict with the technical specifications.

type of product: **NOVAR**..... serial number

date of dispatch: final quality inspection:

manufacturer's seal:

date of purchase: supplier's seal: